

NINZ sliding gates

FIRE DOORS

FEATURES	168 - 171
OPERATING MODE	172
OPTIONAL - MANDATORY ACCESSORIES	173 - 177
PEDESTRIAN DOORS	178 - 179
EXPLOSIVE COMPONENTS DRAWING	180 - 181

Features

Sliding gates

WHAT DEFINES THEM?

REI120 and REI180 fire rated gates are available with horizontal sliding.

The field of application includes the closure of large openings and/or special usage conditions in the dimensions requested by the customer. Gates are supplied with leaves made with flush panels of insulated sheet metal, top tubular tracks, protective carters, counterweights, thermal or electromagnetic fuses and finished with a base coat or RAL colors, plus other accessories required for the correct functioning of the product.

Standards

The gates are certified in accordance with UNI 9723 standard in compliance with the current ministerial provisions in force.

Opening direction

The opening direction needs to be specified when the order is placed.

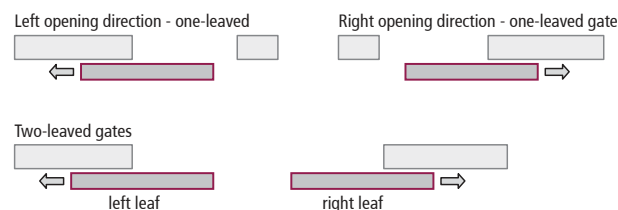

Sliding gates available in the following classes:

REI 120 REI 180



ATTENTION

Fire compartmentalization elements should always be used properly. They are only designed for installation in spaces and constructions that are vertically aligned and flush.

Interior compartmentalization is possible for areas only which are not subject to strong air currents. Installation to be executed by specialized technicians only. For special applications consult with our technical office.

The holding system for the gate is chosen by the customer to conform with their own worksite needs and the anti-fire design (thermal fuse or electromagnet).

Two-leaved gates available in the following classes:

REI 120



NOTE

Fire rated gates require careful design because of their dimensions and special functions. Every installation site should be measured and checked for vertical alignment of the walls and gradients of the flooring. Particular care must be taken to check for protrusions or blockages that might hinder the

operation or free movement of the gates. Given the considerable weight of gates, the bearing capacity of the walls and crossbeams involved should be checked for the mounting of top guide tracks and overlapping labyrinths.

Features

Sliding gates

REI 120 ONE-LEAVED VERSION

In conformity with UNI 9723, the sliding gates series has the following features:

Installation

On weight-bearing masonry walls or insulated steel or insulated steel structures.

Gate leaves

Made of continuous panels of hollow-core sheet metal insulated with appropriate materials. Assembly involves screwing the structure to pre-prepared horizontal profiles. Leaf thickness 80 mm.

Top guide track

For horizontal sliding, made of press-folded steel with pre-drilled holes for attachment using plugs (not included). Overhead sliding on low friction carriages. The extension of the floor-mounted guide track beyond the opening ensures the perpendicularity of the leaf. The top guide track is covered by a protection carter made of press-folded sheet metal.

Overlapping labyrinths

Made of press-folded steel.

Counterweight

For adjustable closure and protected by press-folded sheet metal carters, with counterstrike inset.

Door handles

Recessed on both sides.

Sealing

Thermo-expanding on all overlapping labyrinths and underneath the leaf.

Identification plate

Marking with reference information that is applied directly to the handle.

Finishing

With a base coat thermoset in a 160 degree °C furnace, light turquoise pastel color (similar to NCS4020-B50G).

Packaging

Modules in disposable metal container.

Wall opening dimensions

Min. 750 x 500 mm, max. 6000 x 6000 mm (larger sizes on request).

Operation mode

Of the gate series with thermal fuse: the gate can stand still at any position. The counterweight remains hooked to the thermal fuse and only closes the gate when the fuse fails.

Weight

Of the sliding door: REI 120 approx. 50 kg/m² of wall opening.

NOTE

Additional accessories are usually dependent on the dimensions of the gates

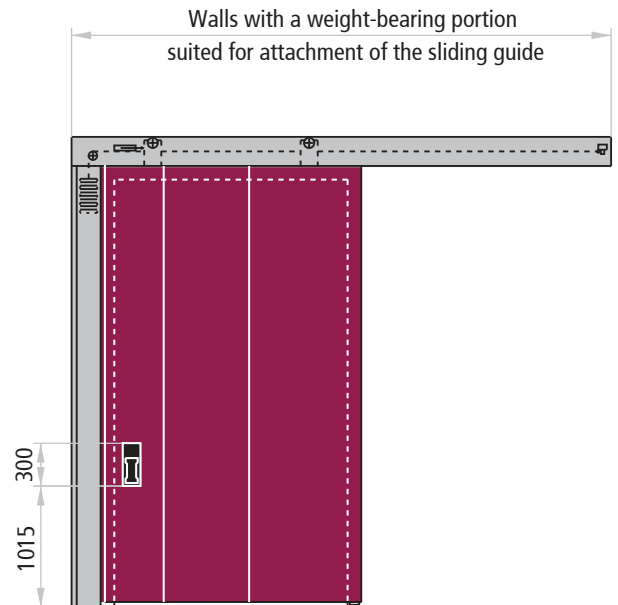

NB: Guide track gradient of 2 mm/running meter

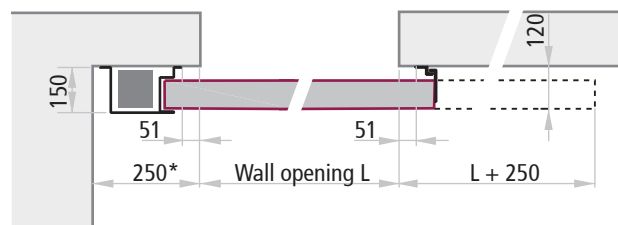
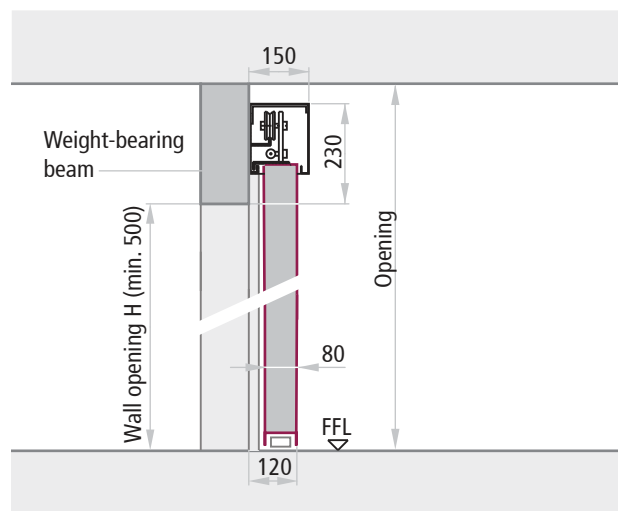

*Variable dimensions for larger-sized gates

Features

Sliding gates

REI 180 ONE-LEAVED VERSION

In conformity with UNI 9723, the sliding gates series has the following features:

Installation

On walls consisting of weight-bearing masonry.

Gate leaves

Made of continuous modules of hollow-core sheet metal panels insulated with the appropriate materials. Assembly involves screwing the structure to pre-prepared horizontal profiles. Leaf thickness 140 mm.

Top guide track

For horizontal sliding, made of press-folded steel with pre-drilled holes for attachment using plugs (not included). Overhead sliding on low friction carriages. The extension of the floor-mounted guide track beyond the opening ensures the perpendicularity of the leaf. The top guide track is covered by a protection carter made of press-folded sheet metal.

Overlapping labyrinths

Made of press-folded steel.

Counterweight

For adjustable closure and protected by press-folded sheet metal carter, with counterstrike inset.

Door handles

Recessed on both sides.

Sealing

Thermo-expanding on all overlapping labyrinths and underneath the leaf.

Identification plate

Marking with reference information that is applied directly to the handle.

Finishing

With a base coat thermoset in a 160 degree °C furnace, light turquoise pastel color (similar to NCS4020-B50G).

Packaging

Modules in disposable metal container.

Wall opening dimensions

Min. 750 x 500 mm, max. 6000 x 6000 mm (larger sizes on request).

Operation mode

Of the gate series with thermal fuse: the gate can stand still at any position. The counterweight remains hooked to the thermal fuse and only closes the gate when the fuse fails.

Weight

Of the sliding door: REI 180 approx. 75 kg/m² of wall opening

NOTE

Additional accessories are usually dependent on the dimensions of the gates

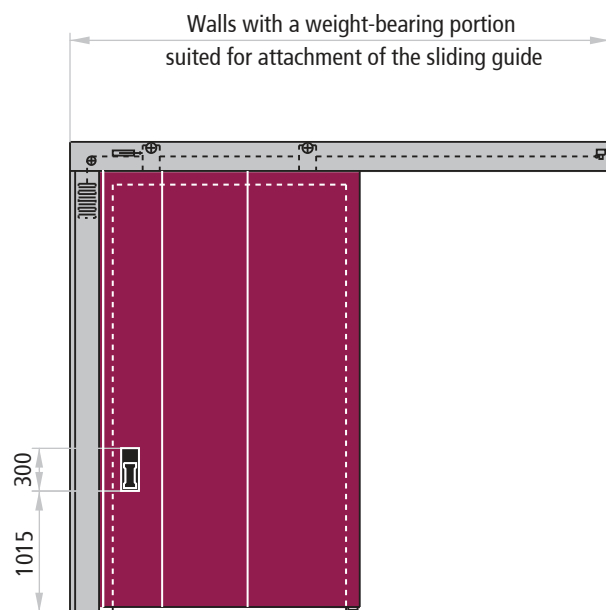

NB: Guide track gradient of 2 mm/running meter

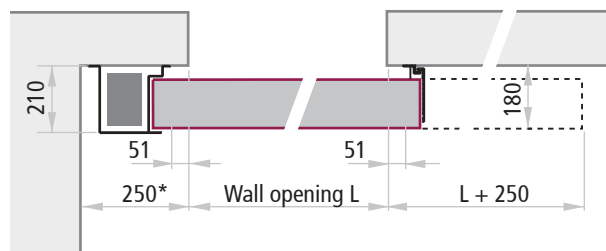
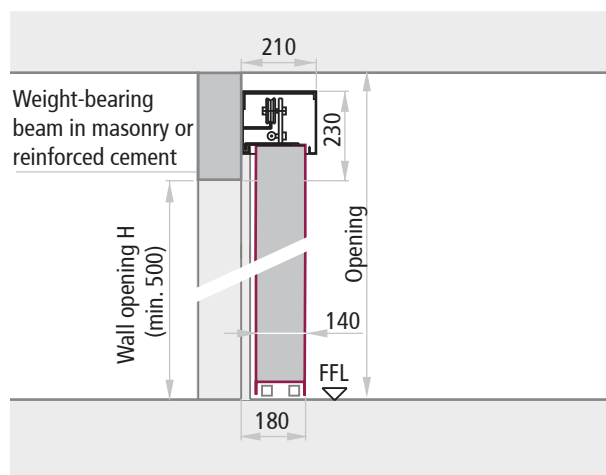

*Variable dimensions for larger-sized gates

REI 120 TWO-LEAVED VERSION

In conformity with UNI 9723, the sliding gates series has the following features:

Application

On weight-bearing masonry walls or insulated steel or insulated steel structure.

Gate leaves

Made of continuous modules of hollow-core sheet metal panels insulated with the appropriate materials. Assembly involves screwing the structure to pre-prepared horizontal profiles. Leaf thickness 80 mm.

Top guide track

For horizontal sliding, made of press-folded steel with pre-drilled holes for attachment using plugs (not included). Overhead sliding on low friction carriages. The extension of the floor-mounted guide track beyond the opening ensures the perpendicularity of the leaves. The top guide track is covered by a protection carter made of press-folded sheet metal.

Overlapping labyrinths

Made of press-folded steel.

Counterweights

For adjustable closure and protected by press-folded sheet metal carters.

Door handles

Recessed on both sides of the leaves.

Sealing

Thermo-expanding on all overlapping labyrinths and underneath the leaves.

Identification plate

Marking with reference information that is applied directly to the handle.

Finishing

With a base coat thermoset in a 160 degree °C furnace, light turquoise pastel color (similar to NCS4020-B50G).

Packaging

Modules in disposable metal container.

Wall opening dimensions

Min. 2000 x 500 mm, max. 8000 x 6000 mm (larger sizes on request).

Operation mode

Of the gate series with thermal fuse: the leaves stand still at any position. The counterweights remain hooked to the related thermal fuse and only close the gate when the fuse fails.

Weight

Of the sliding door: REI 120 approx. 50 kg/m² of wall opening.

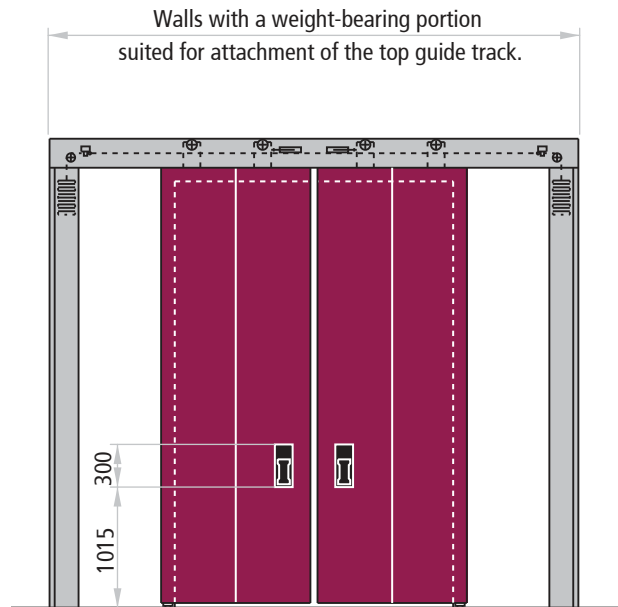

NB: Guide track gradient of 2 mm/running meter
Also executable with unequal leaves

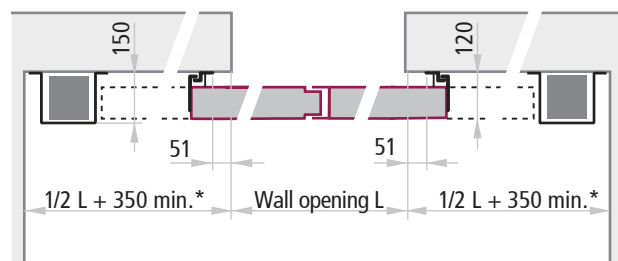
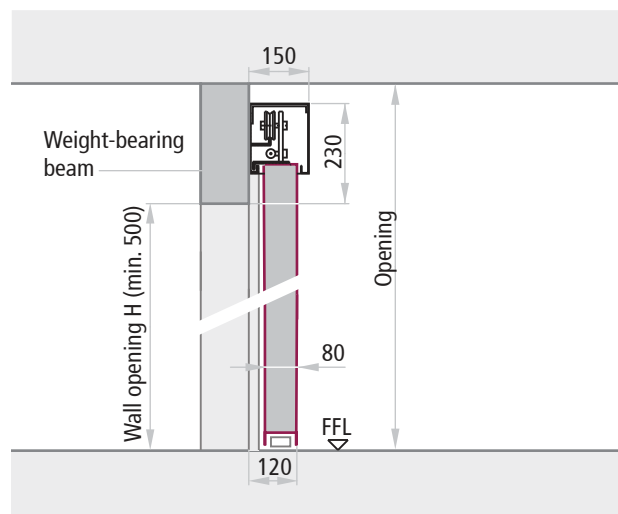

*Variable dimensions for larger-sized gates

NOTE

Additional accessories are usually dependent on the dimensions of the gates

Operation mode

Sliding gates

OPERATION MODE OF SLIDING FIRE GATES WITH ONE OR TWO LEAVES

The selection of the holding system should reflect the customer's worksite needs and the anti-fire project.

Operation mode of gates equipped with thermal fuse:

The counterweight (1) does not load the gate and the operator (2) manually opens and closes the gates, which remains in the position it is left in. When the thermal fuse (3) is subjected to temperatures greater than 70° C, it breaks and causes the cable (4) to be released, so that the counterweight drags the gates to the closed position. The feed speed brake (5) prevents the gates from accelerating during closure. The feed-in impact absorber (6) softens the final feed-in impact of the closure.

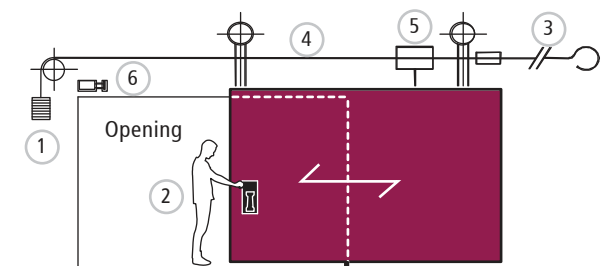

NOTE

The thermal fuse is only triggered when the temperature in the immediate vicinity rises above 70° C, and it does not respond to smoke. Its application, therefore, is not advisable when the gates are located outside the compartmentalization space and when a reaction to cold smoke is required.

Operation mode of gates equipped with electromagnet:

The counterweight (1) continuously loads the gate. The gate usually remains open, held in place by the electromagnet (2). The counterweight closes the gate whenever the electromagnet lacks impulse current from the control unit or when the release button (3) is pressed. The feed speed brake (4) prevents the gate from accelerating during closure. The feed-in impact absorber (5) softens the final feed-in impact of the closure. The electromagnet must be connected with a power control unit and the related external smoke and heat detectors.

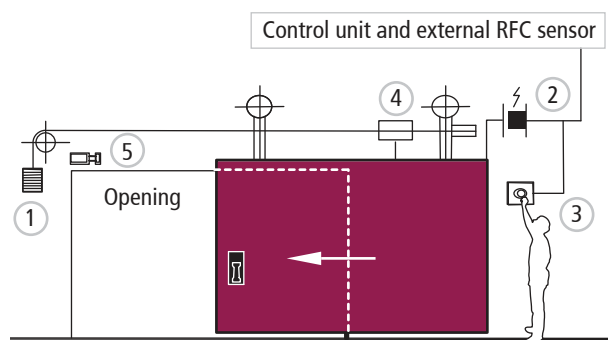

NOTE

The gate closes on impulse from a control unit controlled by an external RFC detector, thus permitting automatic closure at temperatures lower than 70° C as well in the presence of cold smoke. This means that the gate can be installed in any position, even outside the compartmentalization space.

TOP GUIDE TRACK

Detail of the upper guide track for one and two-leaved sliding gates. The heights refer to wall openings which are

perfectly vertically aligned, installed properly and the values of the drawing should be considered approximate.

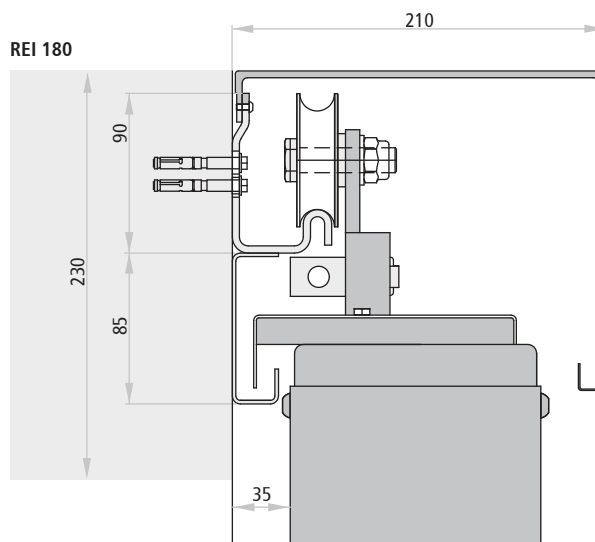
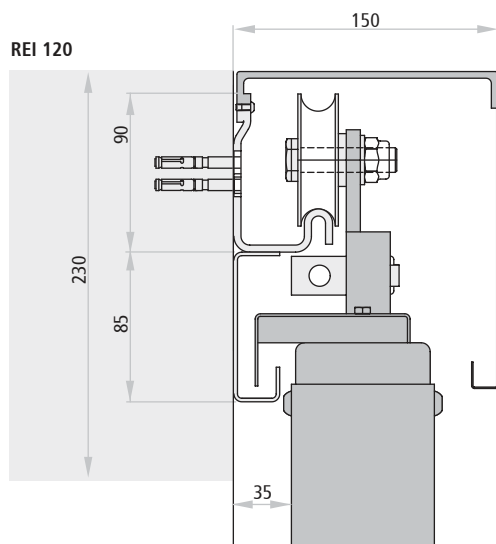

PAINTING

With ecologically formulated anti-corrosive epoxide primer. Minimum resistance to salt fog exposure: 300 hours (A.S.T.M. B - 117 - 61). Basic anti-corrosion coating: Light turquoise pastel.

Group 01 (Basic anti-corrosion coating only):

Light turquoise pastel
(similar to NCS4020-B50G)

RAL
7035



Group 02 (Basic anti-corrosion coating + satin topcoat finishing):

RAL 1001	RAL 1013	RAL 1015	RAL 3000	RAL 3003	RAL 3020	RAL 5010	RAL 5012
RAL 5015	RAL 5024	RAL 6000	RAL 6005	RAL 7001	RAL 7004	RAL 7011	RAL 7016
RAL 7024	RAL 7030	RAL 7032	RAL 7035	RAL 7037	RAL 7038	RAL 7040	RAL 7042
RAL 7047	RAL 8011	RAL 8017	RAL 8019	RAL 9001	RAL 9002	RAL 9005	RAL 9010
RAL 9011	RAL 9016	RAL 9018					

In general, all RAL colours are useable except for: RAL 1018, RAL 5005 and RAL 9007

Cleaning

Water and neutral soap are recommended for the regular cleaning of our products. Do not use common cleaning products (see detergents) and/or other solvents. We shall not be held responsible for any problems that arise if these guidelines are not respected.

Re-painting

For re-painting, use the following procedure:

- sand and carefully wipe away any dust from the surfaces
- apply a base layer of opaque 2-component epoxide we recommend EPOX product Nr. 5203 beige 0059 made by ALCEA in Milan
- repaint the surfaces with your choice of lacquers or paints.



Group 03 (Basic anti-corrosion coating + satin topcoat finishing):

RAL 1004	RAL 1005	RAL 1006	RAL 1007	RAL 9006*
-------------	-------------	-------------	-------------	--------------

*Pre-approval of the sample is required.

Group 04 (Basic anti-corrosion coating + satin topcoat finishing):

RAL 1003	RAL 1012	RAL 1016	RAL 1021	RAL 1023	RAL 5002
-------------	-------------	-------------	-------------	-------------	-------------

Group 05 (Basic anti-corrosion coating only):

Basic anti-corrosion coating is available for all colors listed in group 02.

NOTE

Due to artifacts of the printing process, the colors depicted here may not correspond exactly to the colors of actual doors. Please see the RAL or NCS samples.

Retouching

On request, Ninz also provides touch-up paint (nitro/synthetic) in 1,00 kg cans in the necessary RAL colour.

Protection

Since the gates are designed for internal usage, they should always be protected from atmospheric agents and direct sunlight.

Exterior uses require paints that are specially designed for this type of use (on request).

ATTENTION

External installation of gates require various measures for preventing product degradation, such as:

1. The gates should always be protected from bad weather. Permanent damage may result if water seeps inside the door leaf. Provide canopies or roofing to protect newly installed and existing products.
2. Avoid darker colors for gates which will be exposed to direct sunlight. Sheet metal can heat up and cause warping of the door leaf which could compromise the functionality of the door itself.

PULLEY TACKLES FOR SELF-CLOSURE

Pulley tackles serve to ensure the full self-closure of sliding gates which are wider than they are tall.

Maximum width WITHOUT TACKLES: $(H-800) \times 2$

Normal pulley tackles

2 pulleys and standard counterweight box:

- for gates wider than $(\text{height } H - 800) \times 2$ and shorter than $(\text{height } H - 800) \times 4$
- minimum space required on rebate side 250 mm
- for geared counterweight: required space on the opening side $L + 400$ mm

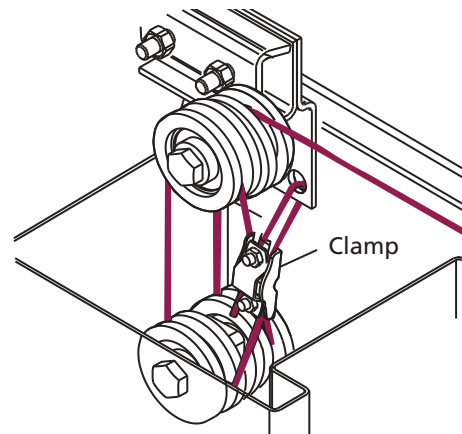

Normal/special pulley tackles

Special pulley tackles

2 pulleys and augmented counterweight box:

- for gates wider than $(\text{height } H - 800) \times 4$ and shorter than $(\text{height } H - 1150) \times 6$
- minimum space required on rebate side 350 mm
- for geared counterweight: required space on the opening side $L + 500$ mm

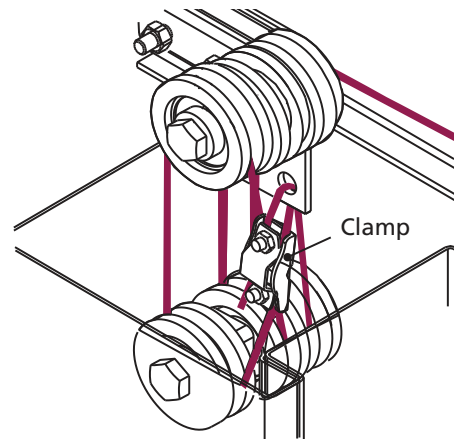

R pulley tackles

R pulley tackles

3 pulleys and larger counterweight box:

- for gates wider than $(\text{height } H - 1150) \times 6$ and shorter than $L=7000$ mm
- minimum space required on rebate side 350 mm
- for geared counterweight: required space on the opening side $L + 500$ mm

VT - VISCOTROLER® ACCIDENT PREVENTION DEVICE

Gates should always be equipped with an automatic device that controls the feed speed of the door during automatic closing.

After the critical moment when automated re-closure has been initiated, door speed increases progressively in proportion to opening time and door weight. During emergency situations, the energy that develops could cause serious injury/damage to people or objects within its range of motion. The hydraulic V.T. VISCOTROLLER® rotor makes it possible to set a constant closing speed in the range of 0.05 to 0,25 m/sec.

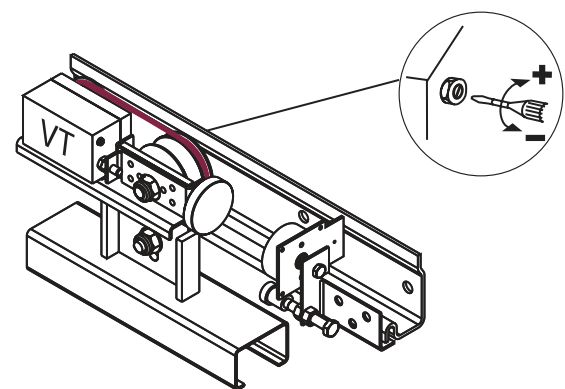

ATTENTION

For purposes of accident prevention, gates should always be equipped with a feed-in brake to regulate closing speed. Customers who choose not to include the feed-in brake assume full responsibility for possible consequences.

Mandatory and optional accessories

Sliding gates

FEED-IN IMPACT ABSORBER

Mandatory accessory for one- and two-leaved sliding gates. Compression energy on the shaft is absorbed by slowing the flow of a fluid by means of an adjustable limiter valve. The shock absorber of the shaft is re-armed when the gate is re-opened.

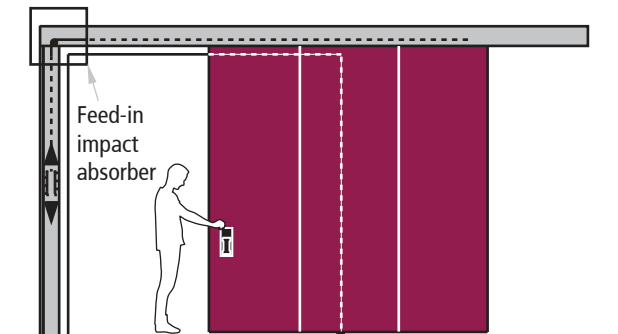
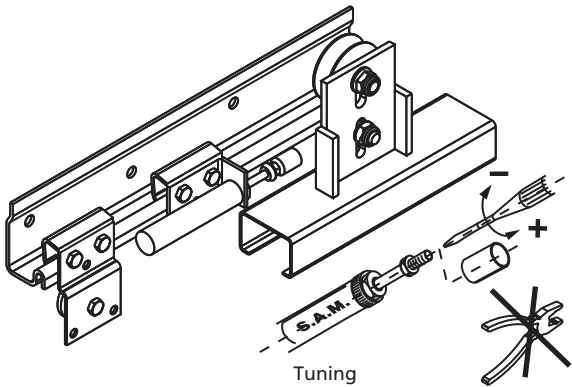

ATTENTION: be careful not to damage the impact absorber shaft

ELECTROMAGNETS

Gates operation mode with electromagnets (on request): the gate is usually left open. The counterweight is always hooked to the leaf and closure occurs whenever the electric current to the electromagnet is interrupted. For smoke/heat detection systems, control unit and power supply, see the dedicated page in the accessories doors section of the present brochure.

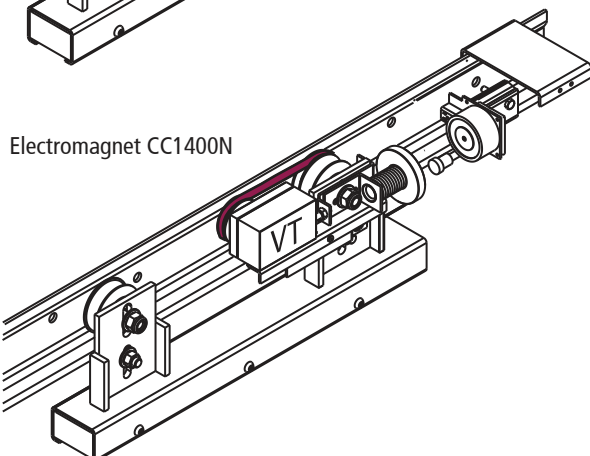
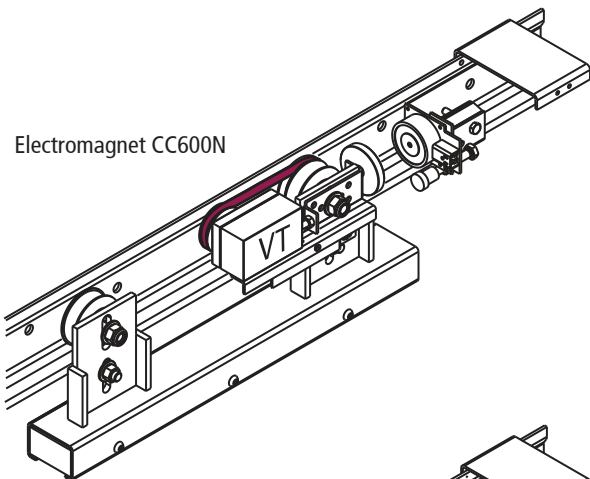

L + 200 (Normal counterweight)
L + 350 (Geared counterweight)

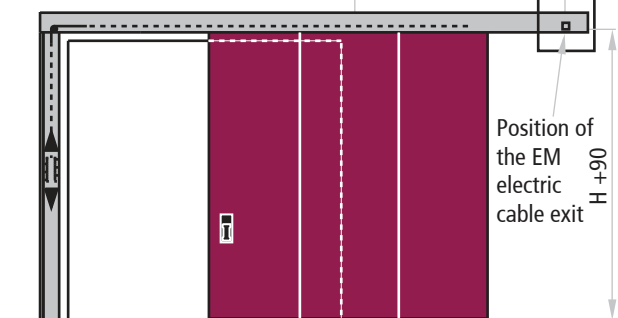

Technical data for the CC600N electromagnet per leaf up to 12 m² of wall opening

primary power supply	24 V DC
voltage tolerance	± 10%
nominal current	125 mA
nominal power	3 W
insertion duration	100%
withstand force	approx. 61 Kg.
operational temperature	0°C ÷ +50°C
operational temperature at 20°C	45°C
magnetic residue	null

Technical data for the CC1400N electromagnet per leaf >12 <30 m² of wall opening

primary power supply	24 V DC
voltage tolerance	± 10%
nominal current	200 mA
nominal power	5 W
insertion duration	100%
withstand force	approx. 143 Kg.
operational temperature	0°C ÷ +50°C
operational temperature at 20°C	60°C
magnetic residue	null

CE marked in conformity with STANDARD EN 1155.
For gates with area $\geq 30\text{m}^2$ of wall opening, the electromagnets will be CC2800N type with different sizes and technical data.

Optional accessories

Sliding gates



REI 120 AND REI 180 COUNTERWEIGHTS

In case of space limitations on the rebate side, on request sliding gates may also be supplied with counterweights in offset and/or deviated position. A 100 mm overlap of the leaf must be ensured regardless. While ordering, please specify whether the rebate is NORMAL or SPECIAL.

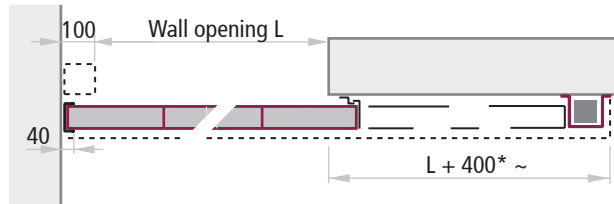

Counterweight version deviated and with normal rebate

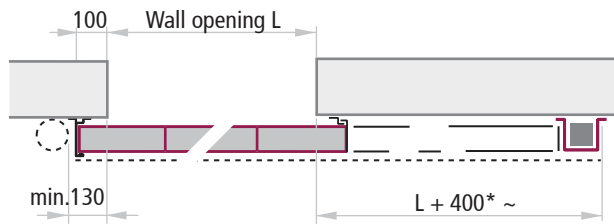

Counterweight version deviated and with special rebate

*Variable dimensions for larger-sized gates.

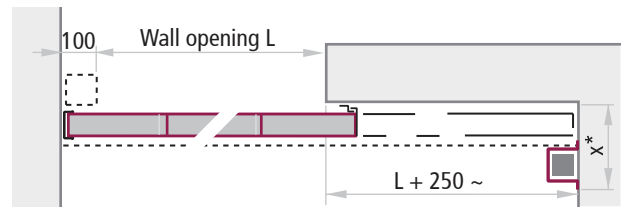

Counterweight version in offset position and deviated
x=330 (REI 120), x=390 (REI 180)

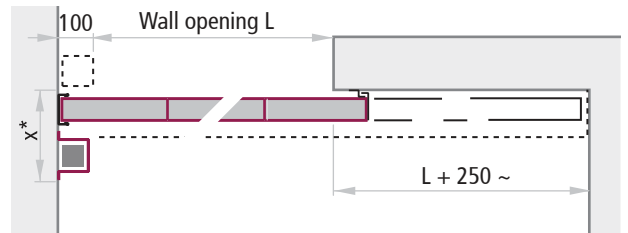

Counterweight version in offset position
x=330 (REI 120), x=390 (REI 180)

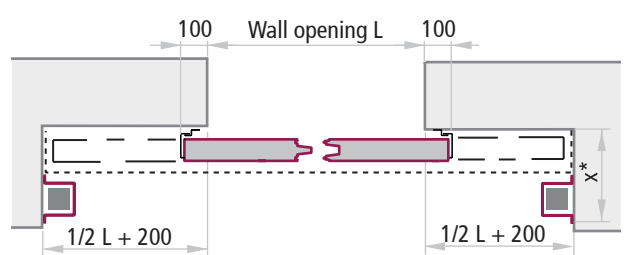

Counterweights version in offset position for REI 120 two-leaved gates

NORMAL/SPECIAL REBATE

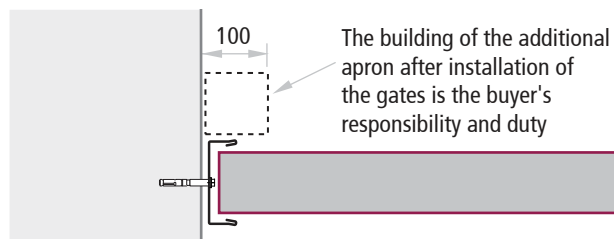

Normal rebate in the presence of a 90° wall

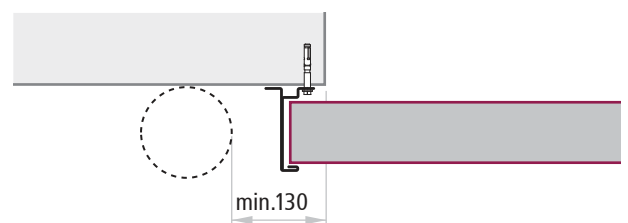

Special rebate in the absence of a 90° wall or any obstacles

Optional accessories

Sliding gates

CROSS BEAM AND WEIGHT-BEARING STRUCTURE

Cross beam made of 100 x 200 mm insulated steel profiles for REI 120 one- or two-leaved sliding gates. Up to L = 2500 ready for lateral attachment, plus additional ceiling attachment for greater widths. Covering/finishing of the beam with 2 sheets of 12.5 mm plasterboard is the customer's responsibility.

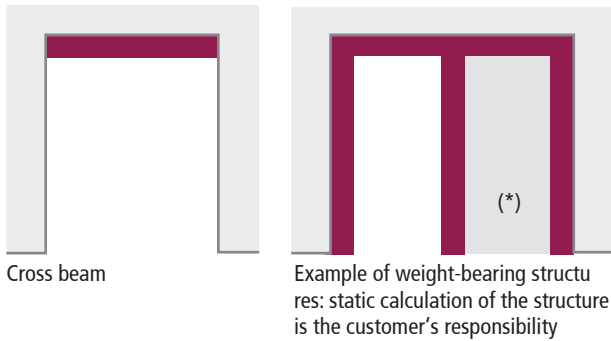

(*) These profiles may also be used for the construction of a weight-bearing structure. Spaces between the various profiles outside of the span may be closed with any REI 120 wall type (plasterboard, panels, etc.)

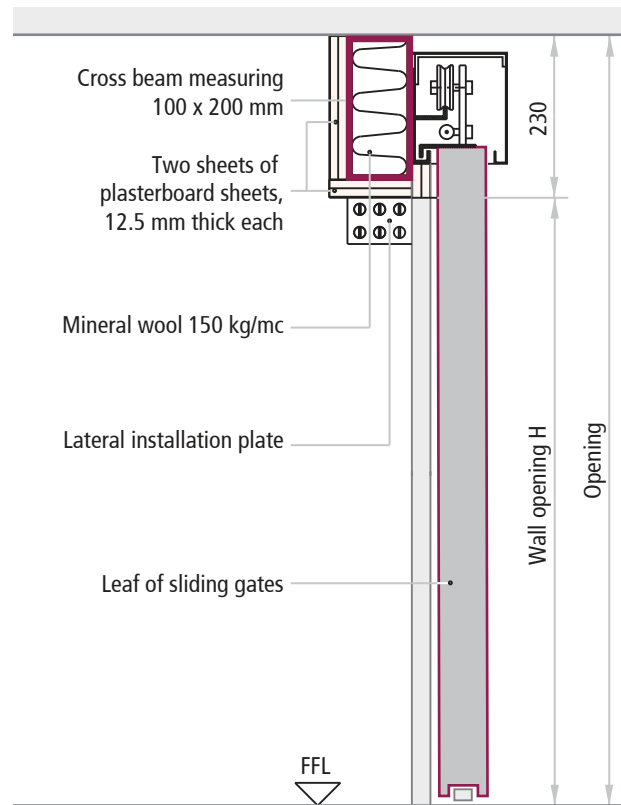

SLIDING
gates

INTERNAL NIGHT LOCK

On request, Sliding gates may be equipped with night locks with cylinders to pass. Utilization of this type of mechanism with gates should be indicated while ordering.

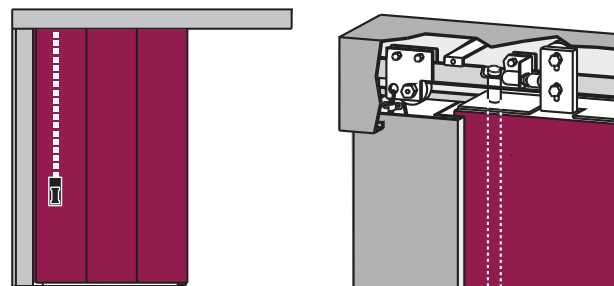

EXTERNAL NIGHT LOCK

The presence of external night lock on gates need not necessarily be indicated during the ordering phase, and is only useable from the side illustrated in the drawing.

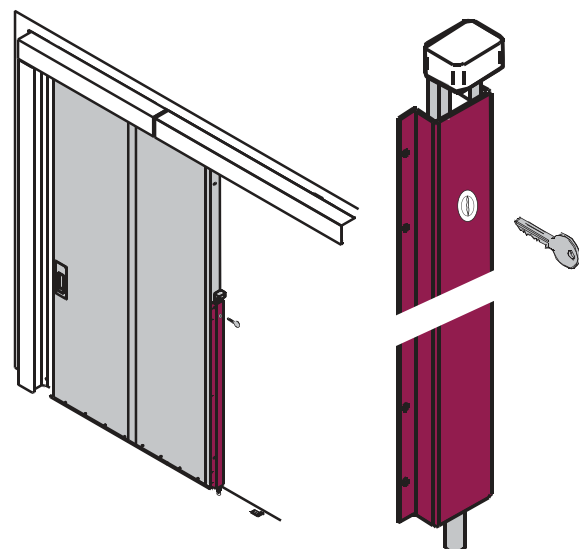

Pedestrian door

Sliding gates

PEDESTRIAN DOOR

REI 120 sliding gates, with one or two leaves, may be equipped with a pedestrian door with or without a lower threshold. Pedestrian doors with thresholds and panic bars are not suitable for escape routes. The right or left opening direction should be specified by the customer during the ordering phase. By default pedestrian doors are inserted in the second panel, which is next to the panel with the handle. For additional information about the SLASH panic exit device, please see the dedicated pages in the panic exit device section of the present brochure.

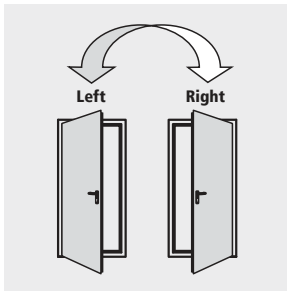

Opening direction



SLASH panic bar

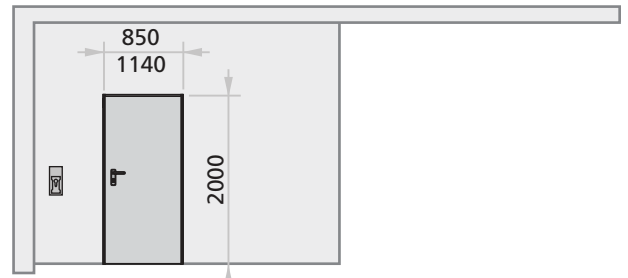

One-leaved gates with pedestrian door without threshold

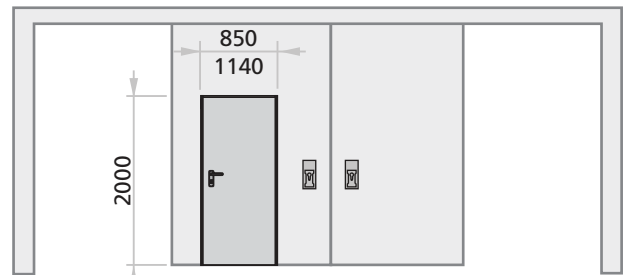

Two-leaved gates with pedestrian door without threshold

Minimum gate dimensions required for insertion of pedestrian doors with or without threshold

Pedestrian door net passage	minimum FM dimensions	
	1-leaved sliding gate	2-leaved sliding gate
width	850 1700	2800
height with threshold	2090	2200*/2250**
height without threshold	2000	2250

* opening on side opposite the wall

** opening on wall side

(please see the drawings on the opposite page)

Pedestrian door with threshold: If the FM H height lower to the measures listed, the height of the pedestrian door is reduced

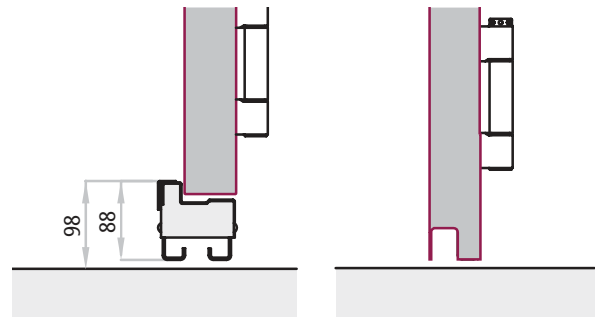

With lower threshold

Without lower threshold

ATTENTION

The threshold version of the pedestrian door with a panic bar is not suited for escape routes.

VERTICAL AND HORIZONTAL SHIMMING

Mandatory for gates with pedestrian doors equipped with panic bars and/or pedestrian doors towards the wall side. The counterweight box and the sliding leaf labyrinths are increased by 60 mm.

NOTE

For two-leaved sliding doors, vertical shimming should be calculated for both leaves.

Shimming needs to be ordered separately.

ATTENTION

*The plasterboard finishing (not included) should be installed on site after the guide track has been installed.

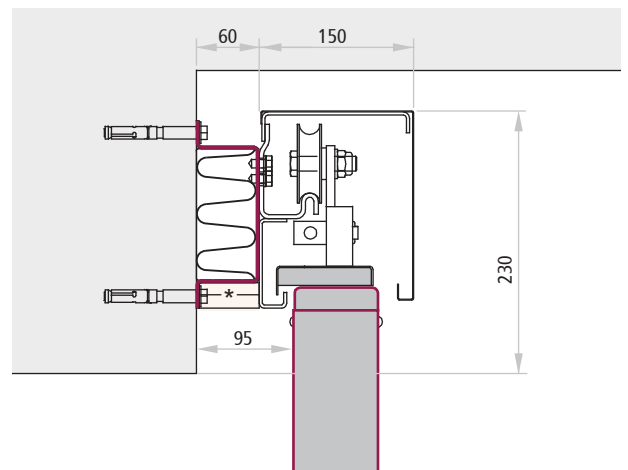

Pedestrian door

Sliding gates

OPENING OF PEDESTRIAN DOOR TOWARDS THE OPPOSITE WALL WITH THE HANDLE

Horizontal and vertical shimming is not necessary.

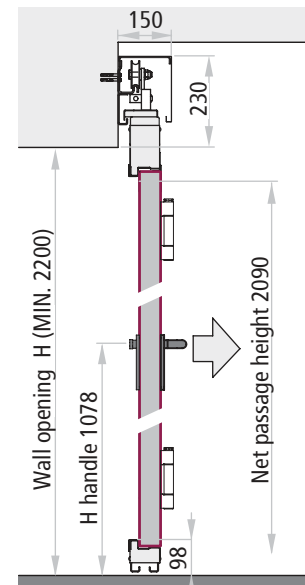
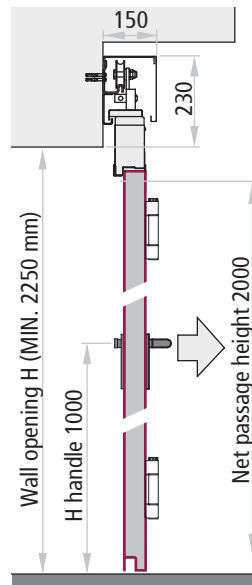
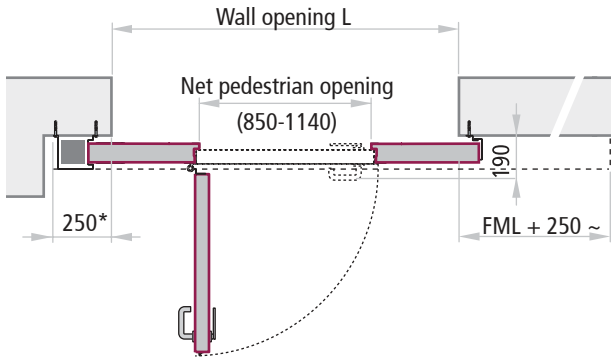

OPENING OF PEDESTRIAN DOOR TOWARDS THE OPPOSITE WALL WITH THE SLASH PANIC BAR

The horizontal and vertical shimming is mandatory.

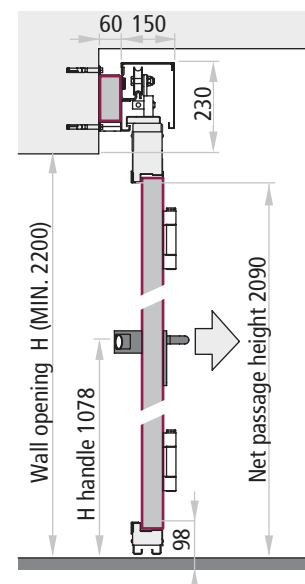
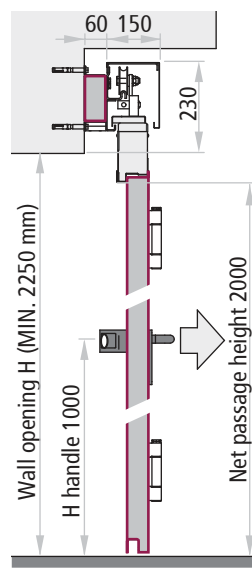
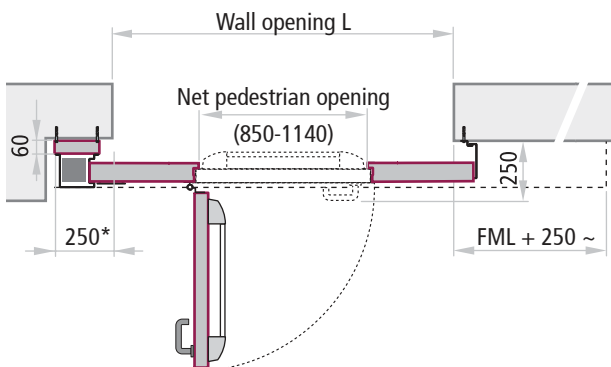

OPENING OF PEDESTRIAN DOOR TOWARDS THE SAME WALL WITH THE SLASH PANIC EXIT DEVICE

The horizontal and vertical shimming is mandatory.

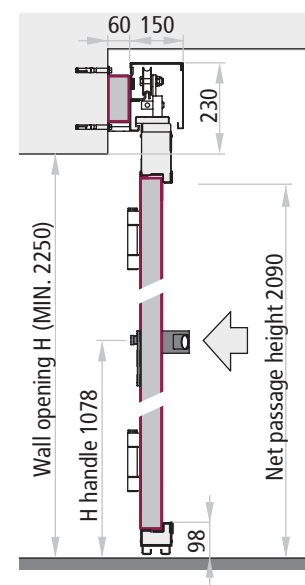
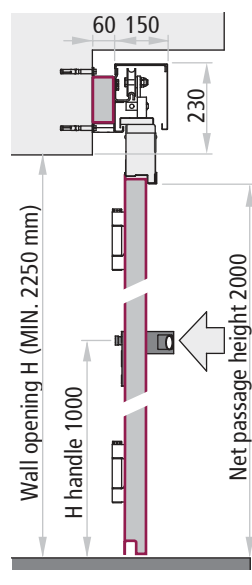
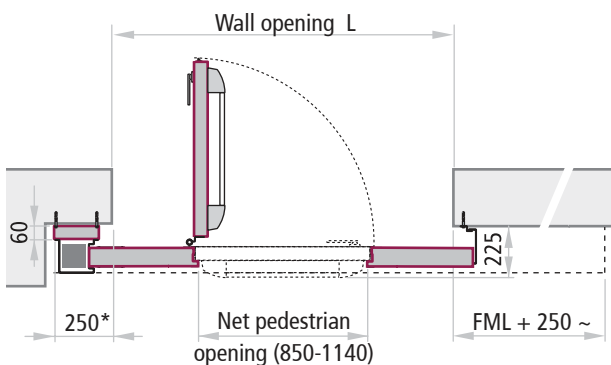

*Variable dimensions for larger-sized gates.

NOTE Pedestrian door with threshold: If the FM H height lower to the

measures listed, the height of the pedestrian door is reduced

SLIDING GATES WITH ONE LEAF

1. panel with handle
2. intermediate panel
3. final panel
4. Z overlapping labyrinth (wall)
5. vertical L overlapping labyrinth (leaf end)
6. horizontal L overlapping labyrinth (upper leaf)
7. horizontal overlapping labyrinth underneath the guide track
8. counterweight box
9. guide track box
10. sliding guide track
11. lower tube
12. upper tube
14. rebate profile for NORMAL returned counterweight
15. rebate profile for SPECIAL returned counterweight
16. pair of lateral caps
17. feed-in impact absorber SAM
18. VT feed speed braking device (brake line belt device)
19. thermal fuse or electromagnet
20. floor-mounted guide track
21. counterweight plate 105x105 or 205x105 mm
22. return pulley standard diam. 60 mm
23. counterweight return pulley returned diam. 50 mm
24. normal carriage diam. 75 mm
25. double-grooved carriage for VT diam. 75 mm
26. cable clamp
27. cable
28. guide-cover support
29. rebate sealing 100 mm
30. Recessed pair of handles
31. End of guiding track device

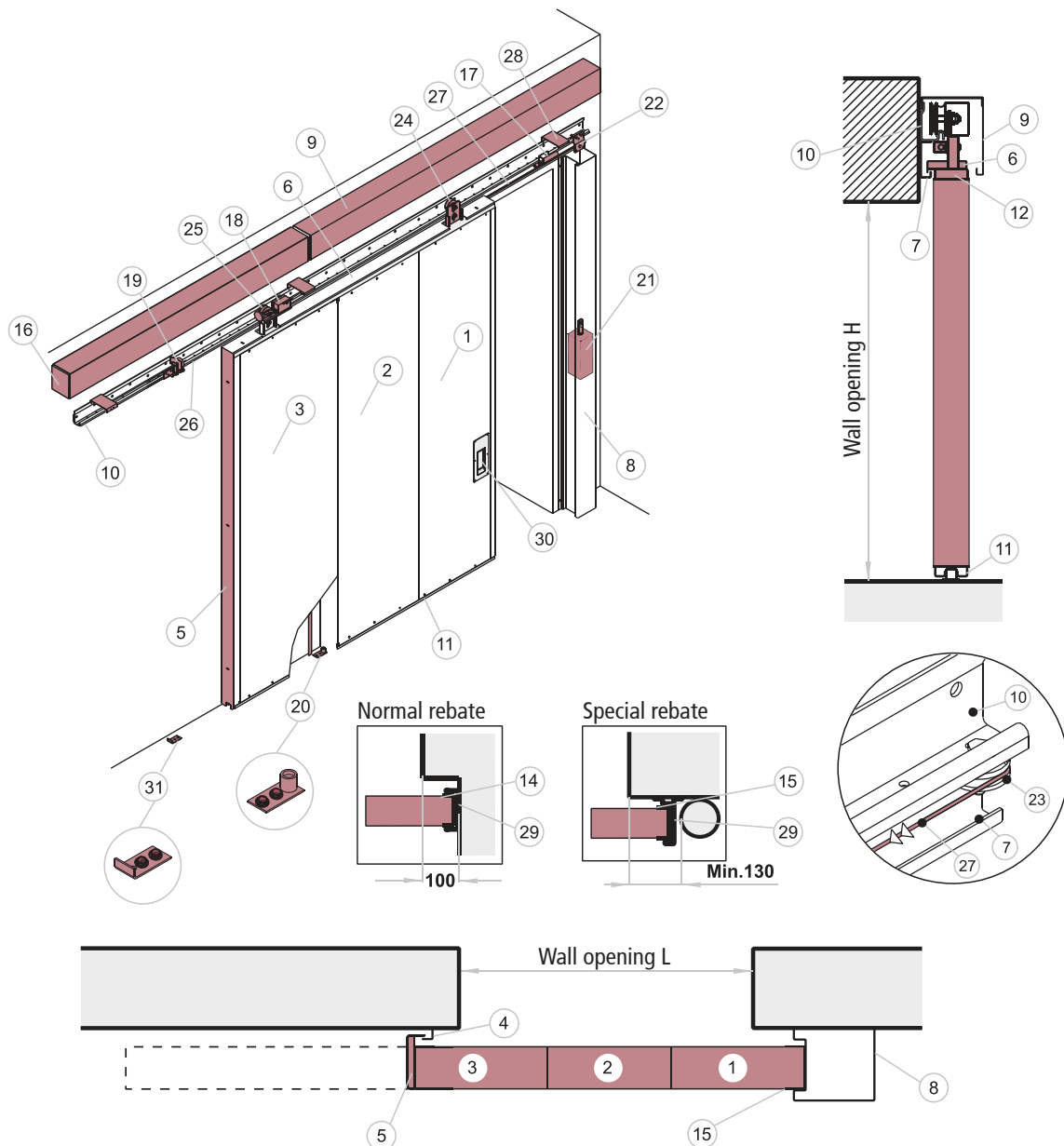

SLIDING GATES WITH TWO LEAVES

- | | |
|---|--|
| 1F. panel with handle, female leaf | 12M. upper tube for male leaf |
| 1M. panel with handle, male leaf | 16. pair of lateral caps |
| 2F. intermediate panel, female leaf | 17. feed-in impact absorber SAM |
| 2M. intermediate panel, male leaf | 18. VT feed-in brake (brake line belt device) |
| 3F. final panel, female leaf | 19. thermal fuse or electromagnet |
| 3M. final panel, male leaf | 20. floor-mounted guide track |
| 4. Z overlapping labyrinth (wall) | 21. counterweight plate 105x105 or 205x105 mm |
| 5. vertical L overlapping labyrinth (leaf end) | 22. return pulley standard diam. 60 mm |
| 6. horizontal overlapping L labyrinth (upper leaf) | 24. normal carriage diam. 75 mm |
| 7. horizontal overlapping labyrinth beneath the guide | 25. double-grooved carriage for VT diam. 75 mm |
| 8. counterweight box | 26. cable clamp |
| 9. guide cover | 27. cable |
| 10. sliding guide track | 28. guide-cover support |
| 11F. lower tube for female leaf | 30. molded pair of handles |
| 11M. lower tube for male leaf | 31. L end of guiding track |
| 12F. upper tube for female leaf | |

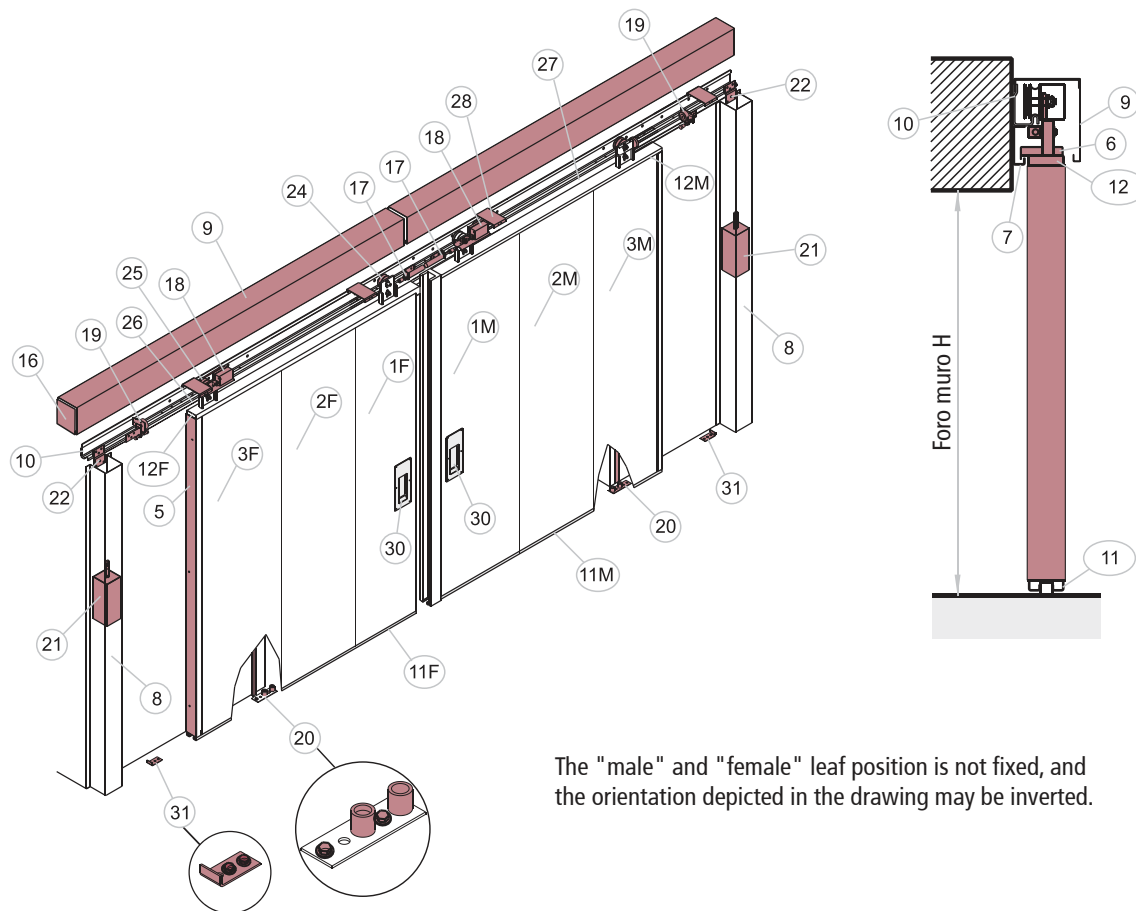

The "male" and "female" leaf position is not fixed, and the orientation depicted in the drawing may be inverted.

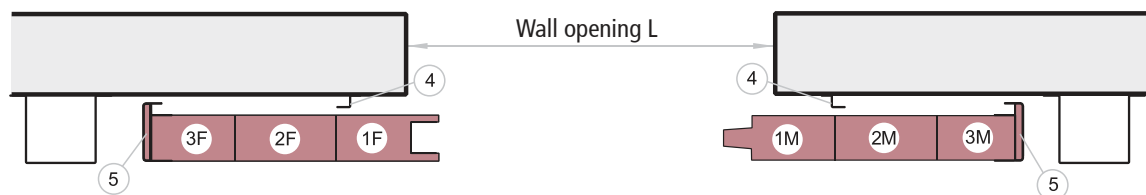

GENERAL NOTES

All rights reserved.
No reproduction (partial or total) without prior authorization by Ninz.
Ninz reserves the right to modify the product.

Installation should be executed by qualified technicians.
Modifications may only be made as indicated in the installation instructions.
Original NINZ replacement parts must be used for all repair work.

**"the ideal solution with
minimal space requirements"**





NINZ telescopic gates

FIRE DOORS

FEATURES	184
REI 120 MONOLATERAL GATES	185
REI 120 BILATERAL GATES	186
OPERATION MODE	187
OPTIONAL - MANDATORY ACCESSORIES	188 - 191

Features

Telescopic gates

WHAT DEFINES THEM?

REI120 telescopic fire rated gates are available as horizontal sliding doors.

The field of use includes large openings and/or special usage conditions in customer-specified dimensions. Gates are supplied with leaves made of flush insulated sheet metal panes, sliding guides, protective carter, counterweights, thermal fuses or electromagnets and finished in a base coat or RAL colors, plus other accessories as required for correct product functioning.

Standards

The gates are certified in accordance with UNI 9723 standard in compliance with the current ministerial provisions in force.

Opening direction

Opening direction needs to be indicated while placing the order.

left opening direction – mono-lateral telescopic gates



Mono-lateral telescopic gates available in class:

REI 120



right opening direction – mono-lateral telescopic gates



Bilateral telescopic gates



Bilateral telescopic gates available in class:

REI 120



NOTE

Fire rated gates require careful design because of their dimensions and special functions. Every installation site should be measured and checked for vertical alignment of the walls and gradients of the flooring. Particular care must be taken to check for protrusions or blockages that might hinder the operation or free movement of the gates. Given the considerable weight of gates, the bearing capacity of the walls and crossbeams involved should be checked for the mounting of top guide tracks and overlapping labyrinths.

ATTENTION

Fire compartmentalization elements should always be used properly. They are only designed for installation in spaces and constructions that are vertically aligned and flush.

Interior compartmentalization is possible for areas only which are not subject to strong air currents. Installation to be executed by specialized technicians only. For special applications consult with our technical office.

The holding system for the gate is chosen by the customer to conform with their own worksite needs and the anti-fire design (thermal fuse or electromagnet).

REI 120 MONOLATERAL VERSION WITH TWO LEAVES

In conformity with UNI 9723 for two leaves, the telescopic mono-lateral gates series has the following features:

Installation

On weight-bearing masonry walls or ceilings.

Gates leaves

Two leaves made of continuous panels of hollow-core sheet metal insulated with appropriate materials. Assembly involves screwing the structure to pre-prepared horizontal profiles. Leaf thickness 80 mm.

Top guide track

For horizontal sliding, made of press-folded steel with pre-drilled holes for attachment using plugs (not included). Overhead sliding on low friction carriages. The extension of the floor-mounted guide track beyond the opening ensures the perpendicularity of the leaf. The top guide track is covered by a protection carter made of press-folded sheet metal.

Overlapping labyrinths

Made of press-folded steel.

Counterweight

For adjustable closure and protected by press-folded sheet metal carters, with counterstrike inset and shimming inset.

Door handles

Recessed on both sides of the first leaf.

Sealing

Thermo-expanding on all overlapping labyrinths and underneath the leaf.

Identification plate

Marking with reference information that is applied directly to the handle.

Finishing

With a base coat thermoset in a 160 degree °C furnace, light turquoise pastel color (similar to NCS4020-B50G).

Packaging

Modules on disposable metal container.

Wall opening dimensions

On request as shown in the table to the side (smaller and larger sizes on request).

Operation mode

Of the gate series with thermal fuse: the gate can stand still at any position. The counterweight remains hooked to the thermal fuse and only closes the gate when the fuse fails.

Weight

For the telescopic gates, approx. 50 kg/m² of wall opening

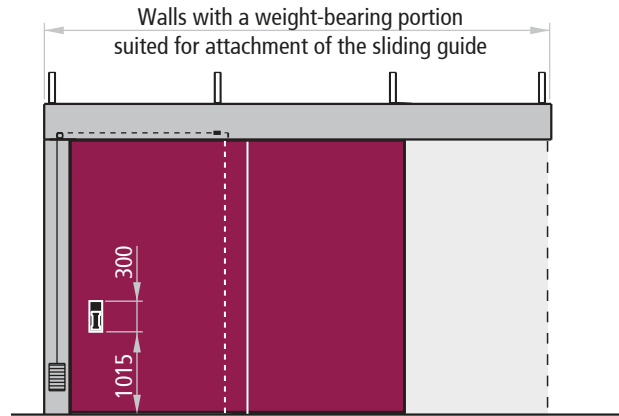

NB: Guide track gradient of 2 mm/running meter

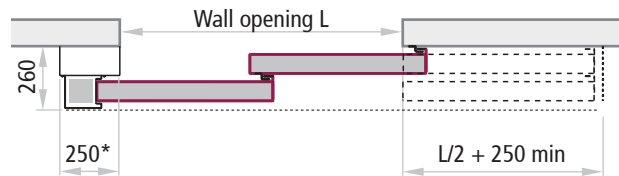

*Variable dimensions for larger-sized gates

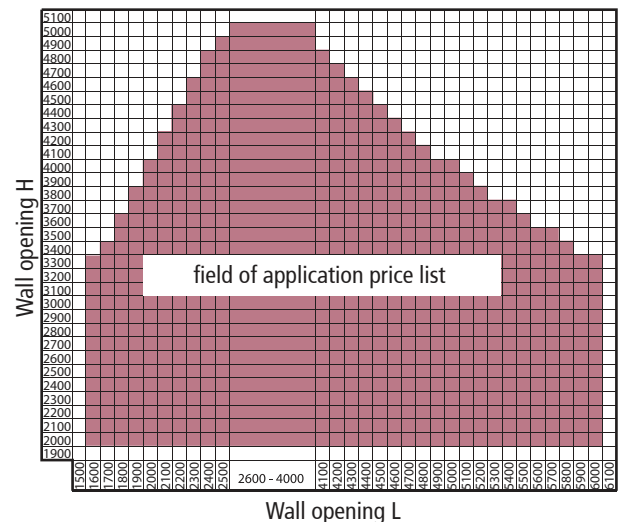
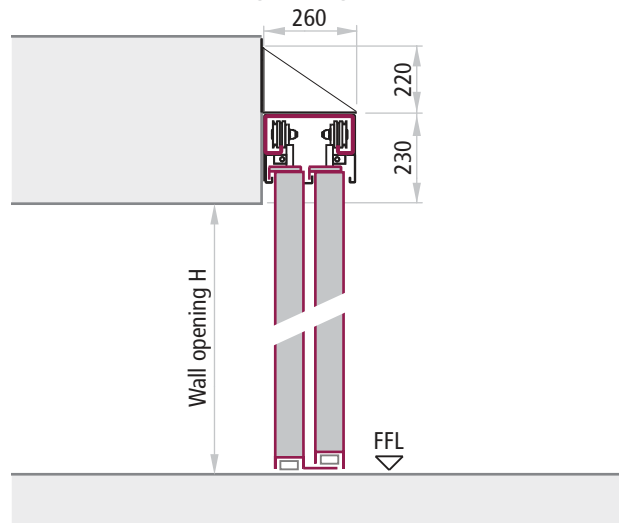

NOTE

Additional accessories are usually dependent on the dimensions of the gates

Features

Telescopic gates

REI 120 BILATERAL VERSION WITH FOUR LEAVES

Conforms with UNI 9723 for four leaves, the telescopic bilateral gates series has the following features:

Installation

On weight-bearing masonry walls or ceilings.

Gate leaves

Four leaves made of continuous modules of hollow-core sheet metal panels insulated with the appropriate materials. Assembly involves screwing the structure to pre-prepared horizontal hollow metal profile. Leaf thickness 80 mm.

Top guide track

Double-guide for horizontal sliding made of press-folded steel with pre-drilled holes for attachment using plugs (not included). Overhead sliding on low friction carriages. The extension of the floor-mounted guide track beyond the opening ensures the perpendicularity of the leaves. The top guide track is covered by a protection carter made of press-folded sheet metal.

Overlapping labyrinths

Made of press-folded sheet metal.

Counterweights

For adjustable closure and protected by press-folded sheet metal carter, with for the counterstrike and shimming insets.

Door handles

Recessed on both sides of the first two leaves.

Sealing

Thermo-expanding on all overlapping labyrinths and underneath the leaves.

Identification plate

Marking with reference information that is applied directly to one of the handles.

Finishing

With a base coat thermoset in a 160 degree °C furnace, light turquoise pastel color (similar to NCS4020-B50G).

Packaging

Modules on disposable metal container.

Wall opening dimensions

On request as shown in the table to the side (smaller and larger measures available on request).

Operation mode

Of the gate series with thermal fuse: the gate can stand still at any position. The counterweight remains hooked to the thermal fuse and only closes the gate when the fuse fails.

Weight

For the telescopic gates, approx. 50 kg/m² of wall opening

NOTE

Additional accessories are usually dependent on the dimensions of the gates

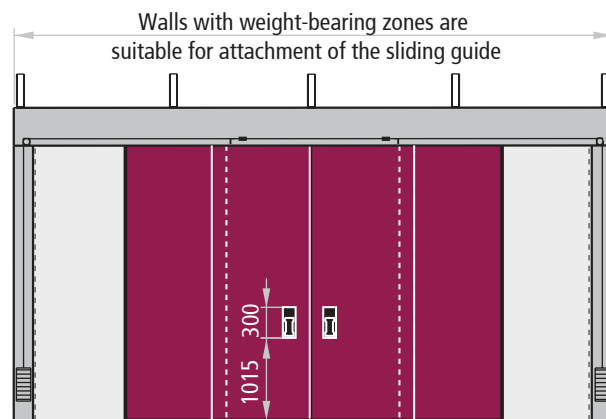

NB: Guide track gradient of 2 mm/running meter

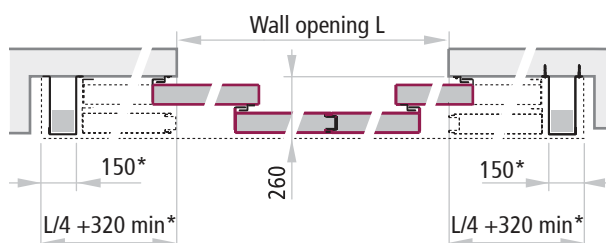

*Variable dimensions for larger-sized gates

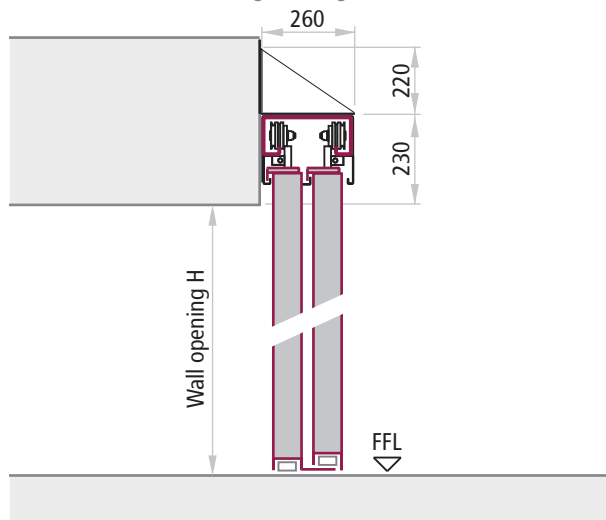

Wall opening H	3200	3300	3400	3500	3600	3700	3800	3900	4000	4100	4200	4300	4400	4500	4600	4700	4800	4900	5000	5100	5200	5300	5400	5500	5600	5700	5800	5900	6000	6100	6200	6300	6400	6500	6600					
4400																																								
4300																																								
4200																																								
4100																																								
4000																																								
3900																																								
3800																																								
3700																																								
3600																																								
3500																																								
3400																																								
3300																																								
3200																																								
3100																																								
3000																																								
2900																																								
2800																																								
2700																																								
2600																																								
2500																																								
2400																																								
2300																																								
2200																																								
2100																																								
2000																																								
1900																																								
Field of application price list																																								
Wall opening L	3200	3300	3400	3500	3600	3700	3800	3900	4000	4100	4200	4300	4400	4500	4600	4700	4800	4900	5000	5100	5200	5300	5400	5500	5600	5700	5800	5900	6000	6100	6200	6300	6400	6500	6600					

Operation mode

Telescopic gates

OPERATION MODE OF TELESCOPIC FIRE GATES

The selection of the holding system should reflect the customer's worksite needs and the anti-fire project.

Operation mode of gates equipped with thermal fuse:

The counterweight (1) does not load the gate and the operator (2) manually opens and closes the gates, which remains in the position it is left in. When the thermal fuse (3) is subjected to temperatures greater than 70° C, it breaks and causes the cable (4) to be released, so that the counterweight drags the gates to the closed position. The feed speed brake (5) prevents the gates from accelerating during closure. The feed-in impact absorber (6) softens the final feed-in impact of the closure.

Operation mode of gates with electromagnet:

The counterweight (1) continuously loads the gate. The gate usually remains open, held in place by the electromagnet (2). The counterweight closes the gate whenever the electromagnet lacks impulse current from the control unit or when the release button (3) is pressed. The feed speed brake (4) prevents the gate from accelerating during closure. The feed-in impact absorber (5) softens the final feed-in impact of the closure. The electromagnet must be connected with a power control unit and the related external smoke and heat detectors.

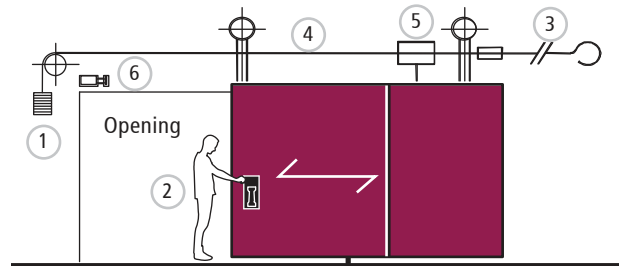

NOTE

The thermal fuse is only triggered when the temperature in the immediate vicinity rises above 70° C, and it does not respond to smoke. Its application, therefore, is not advisable when the gates are located outside the compartmentalization space and when a reaction to cold smoke is required.

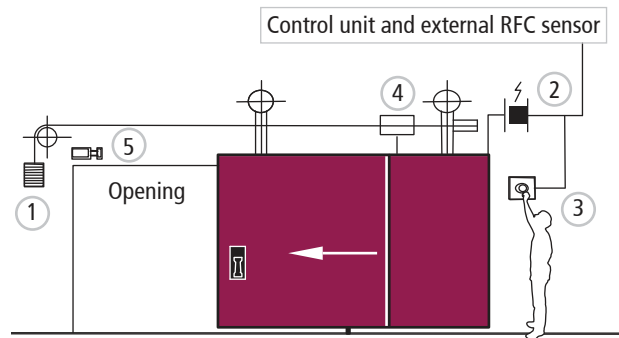

NOTE

The gate closes on impulse from a control unit controlled by an external RFC detector, thus permitting automatic closure at temperatures lower than 70° C as well in the presence of cold smoke. This means that the gate can be installed in any position, even outside the compartmentalization space.

INSTALLATION

Frontal installation

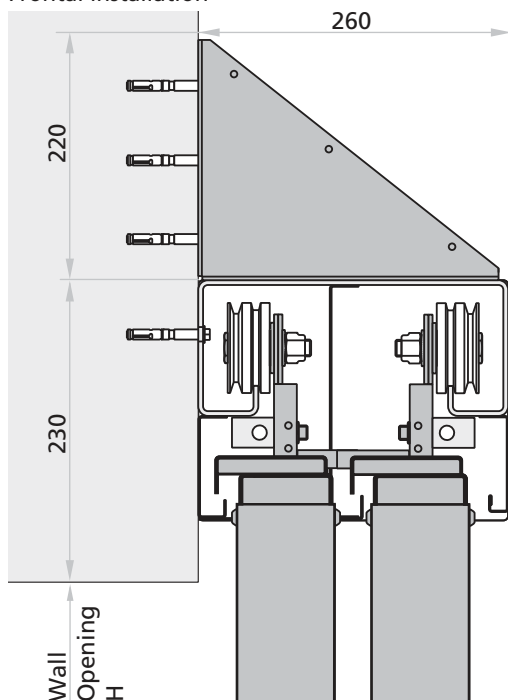

Ceiling attachment

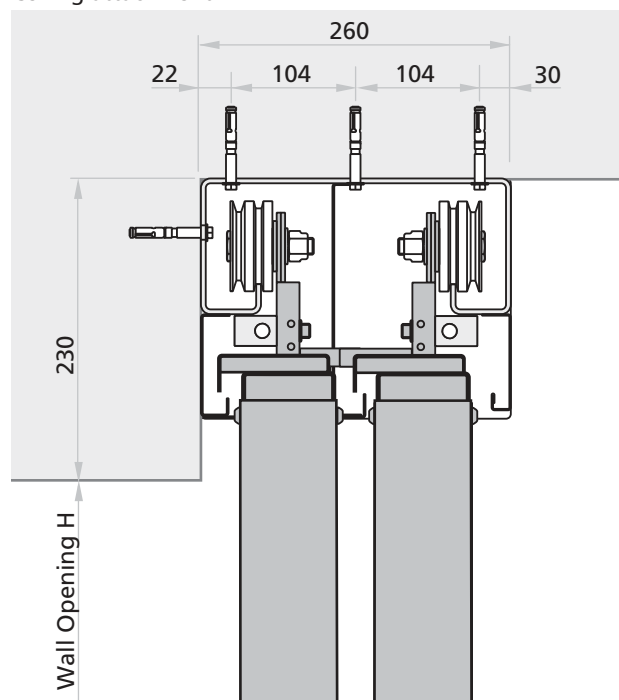

Optional accessories

Telescopic gates

PAINTING

With ecologically formulated anti-corrosive epoxide primer. Minimum resistance to salt fog exposure: 300 hours (A.S.T.M. B - 117 - 61). Basic anti-corrosion coating: Light turquoise pastel.

Group 01 (Basic anti-corrosion coating only):

Light turquoise pastel
(similar to NCS4020-B50G)

RAL
7035

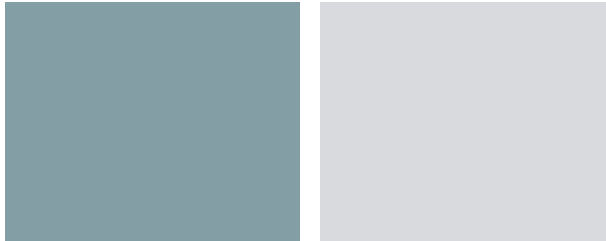

Group 02 (Basic anti-corrosion coating + satin topcoat finishing):

RAL 1001	RAL 1013	RAL 1015	RAL 3000	RAL 3003	RAL 3020	RAL 5010	RAL 5012
RAL 5015	RAL 5024	RAL 6000	RAL 6005	RAL 7001	RAL 7004	RAL 7011	RAL 7016
RAL 7024	RAL 7030	RAL 7032	RAL 7035	RAL 7037	RAL 7038	RAL 7040	RAL 7042
RAL 7047	RAL 8011	RAL 8017	RAL 8019	RAL 9001	RAL 9002	RAL 9005	RAL 9010
RAL 9011	RAL 9016	RAL 9018					

In general, all RAL colours are useable except for: RAL 1018, RAL 5005 and RAL 9007

Cleaning

Water and neutral soap are recommended for the regular cleaning of our products. Do not use common cleaning products (see detergents) and/or other solvents. We shall not be held responsible for any problems that arise if these guidelines are not respected.

Re-painting

For re-painting, use the following procedure:

- sand and carefully wipe away any dust from the surfaces
- apply a base layer of opaque 2-component epoxide we recommend EPOX product Nr. 5203 beige 0059 made by ALCEA in Milan
- repaint the surfaces with your choice of lacquers or paints.



Group 03 (Basic anti-corrosion coating + satin topcoat finishing):

RAL 1004 RAL 1005 RAL 1006 RAL 1007 RAL 9006*



*Pre-approval of the sample is required.

Group 04 (Basic anti-corrosion coating + satin topcoat finishing):

RAL 1003 RAL 1012 RAL 1016 RAL 1021 RAL 1023 RAL 5002



Group 05 (Basic anti-corrosion coating only):

Basic anti-corrosion coating is available for all colors listed in group 02.

NOTE

Due to artifacts of the printing process, the colors depicted here may not correspond exactly to the colors of actual doors. Please see the RAL or NCS samples.

Retouching

On request, Ninz also provides touch-up paint (nitro/synthetic) in 1,00 kg cans in the necessary RAL colour.

Protection

Since the gates are designed for internal usage, they should always be protected from atmospheric agents and direct sunlight.

Exterior uses require paints that are specially designed for this type of use (on request).

ATTENTION

External installation of gates require various measures for preventing product degradation, such as:

1. The gates should always be protected from bad weather. Permanent damage may result if water seeps inside the door leaf. Provide canopies or roofing to protect newly installed and existing products.
2. Avoid darker colors for gates which will be exposed to direct sunlight. Sheet metal can heat up and cause warping of the door leaf which could compromise the functionality of the door itself.

Mandatory accessories

Telescopic gates

PULLEY TACKLES FOR SELF-CLOSURE

Pulley tackles serve to ensure the full self-closure of telescopic gates which are wider than they are tall.

Maximum width WITHOUT TACKLES: $(H-800) \times 2$

Normal pulley tackles

2 pulleys and standard counterweight box:

- for gates wider than $(\text{height } H - 800) \times 2$ and shorter than $(\text{height } H - 800) \times 4$
- minimum space required on rebate side 250 mm
- for geared counterweight: required space on the opening side $L + 400$ mm

Special pulley tackles

2 pulleys and augmented counterweight box:

- for gates wider than $(\text{height } H - 800) \times 4$ and shorter than $(\text{height } H - 1150) \times 6$
- minimum space required on rebate side 350 mm
- for geared counterweight: required space on the opening side $L + 500$ mm

R pulley tackles

3 pulleys and larger counterweight box:

- for gates wider than $(\text{height } H - 1150) \times 6$ and shorter than $L=7000$ mm
- minimum space required on rebate side 350 mm
- for geared counterweight: required space on the opening side $L + 500$ mm

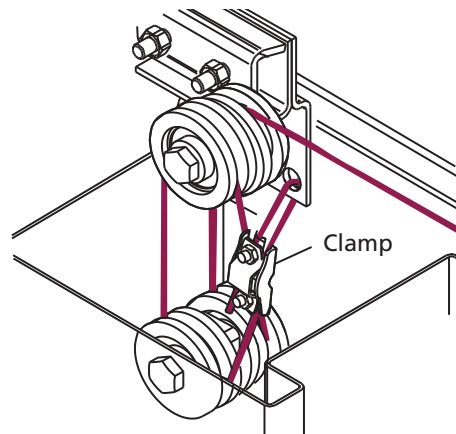

Normal/special pulley tackles

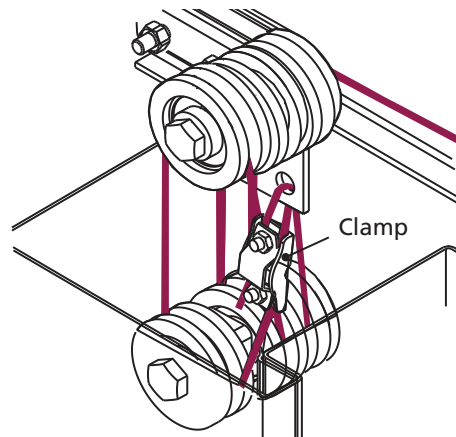

R pulley tackles

VT - VISCOTROLER[®]

ACCIDENT PREVENTION DEVICE

Gates should always be equipped with an automatic device that controls the feed speed of the door during automatic closing.

After the critical moment when automated re-closure has been initiated, door speed increases progressively in proportion to opening time and door weight. During emergency situations, the energy that develops could cause serious injury/damage to people or objects within its range of motion. The hydraulic V.T. VISCOTROLLER[®] rotor makes it possible to set a constant closing speed in the range of 0.05 to 0,25 m/sec.

ATTENTION

For purposes of accident prevention, gates should always be equipped with a feed-in brake to regulate closing speed. Customers who choose not to include the feed-in brake assume full responsibility for possible consequences.

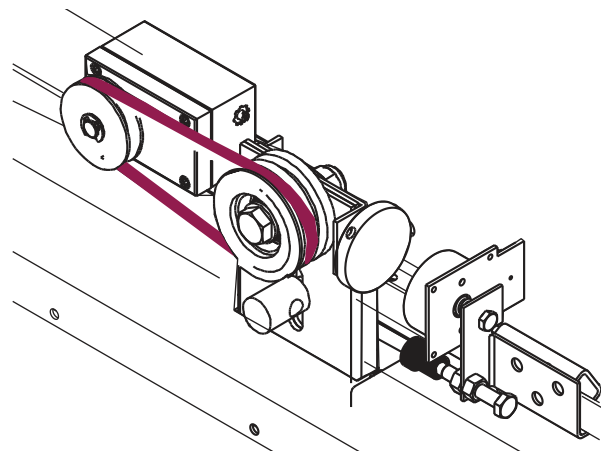

Mandatory and optional accessories

Telescopic gates



TELESCOPIC gates

FEED-IN IMPACT ABSORBER

Mandatory accessory for one- and two-leaved telescopic gates. The compression energy on the shaft is absorbed by slowing the flow of a fluid by means of an adjustable limiter valve. The shock absorber of the shaft is re-armed when the gates is re-opened.

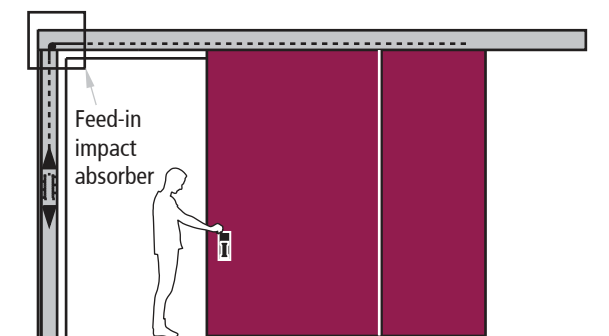
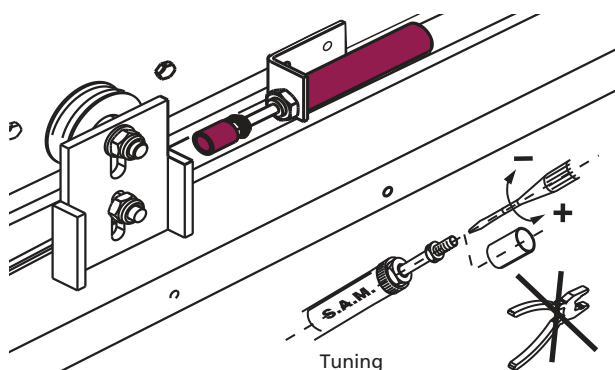

ATTENTION: be careful not to damage the impact absorber shaft

ELECTROMAGNETS

Gates operation mode with electromagnets (on request): the gate is usually left open. The counterweight is always hooked to the leaf and closure occurs whenever the electric current to the electromagnet is interrupted.

For smoke/heat detection systems, control unit and power supply, see the dedicated page in the accessories doors section of the present brochure.

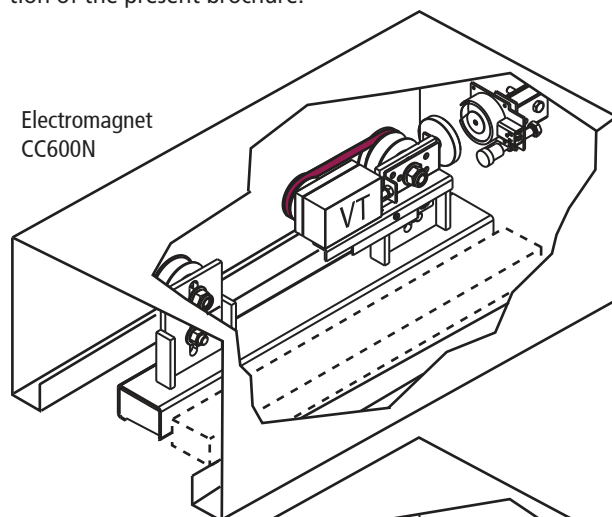

Electromagnet
CC600N

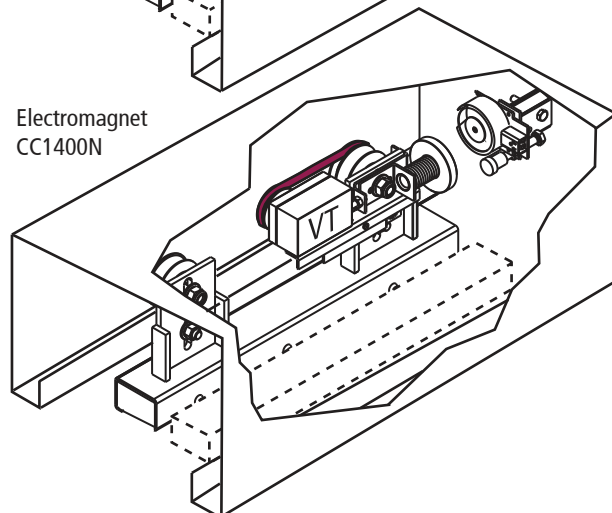

Electromagnet
CC1400N

L/2 + 200 (Normal counterweight)
L/2 + 350 (Delayed counterweight)

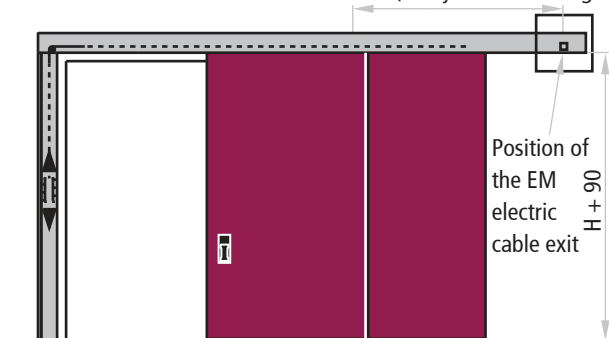

Technical data for the CC600N electromagnet per leaf for up to 12 m² of wall opening

primary power supply	24 V DC
voltage tolerance	± 10%
nominal current	125 mA
nominal power	3 W
insertion duration	100%
withstand force	approx. 61 Kg.
operational temperature	0°C ÷ +50°C
operational temperature at 20°C	45°C
magnetic residue	null

Technical data for the CC1400N electromagnet per leaf >12 <30 m² of wall opening

primary power supply	24 V DC
voltage tolerance	± 10%
nominal current	200 mA
nominal power	5 W
insertion duration	100%
withstand force	approx. 143 Kg.
operational temperature	0°C ÷ +50°C
operational temperature at 20°C	60°C
magnetic residue	null

CE marked in conformity with STANDARD EN 1155.
For gates with area ≥30m² of wall opening, the electromagnets will be CC2800N type with different sizes and technical data.

DEVIATED COUNTERWEIGHTS FOR REI 120 MONOLATERAL TELESCOPIC GATES

In case of space limitations on the rebate side, on request telescopic gates may also be supplied with deviated counterweights.

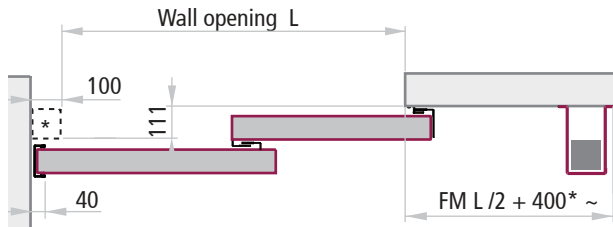

Counterweight version deviated and with normal rebate

*After the gate has been installed, building of the additional apron is the buyer's responsibility and duty

A 100 mm overlap of the leaf must be ensured regardless. While ordering, please specify whether the rebate is NORMAL or SPECIAL.

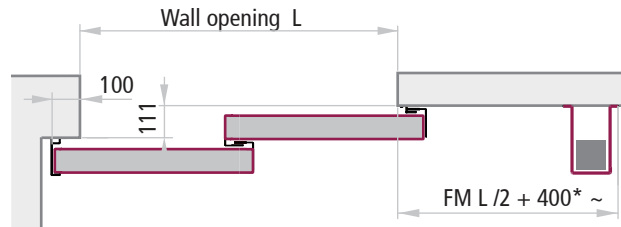

Counterweight version deviated and with special rebate

INTERNAL NIGHT LOCK

On request, telescopic gates may be equipped with night locks with cylinders to pass. Utilization of this type of mechanism with gates should be indicated while ordering.

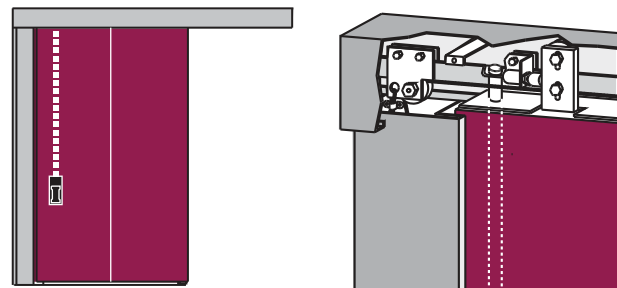

CROSS BEAMS

Cross beam made of 100 x 200 mm insulated hollow metal profile for REI 120 telescopic gates. Up to L = 2500 ready for lateral attachment, plus additional ceiling attachment for greater widths. Covering/finishing of the beam with 2 sheets of 12.5 mm plasterboard is the customer's responsibility.

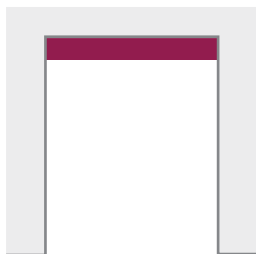

Cross beams

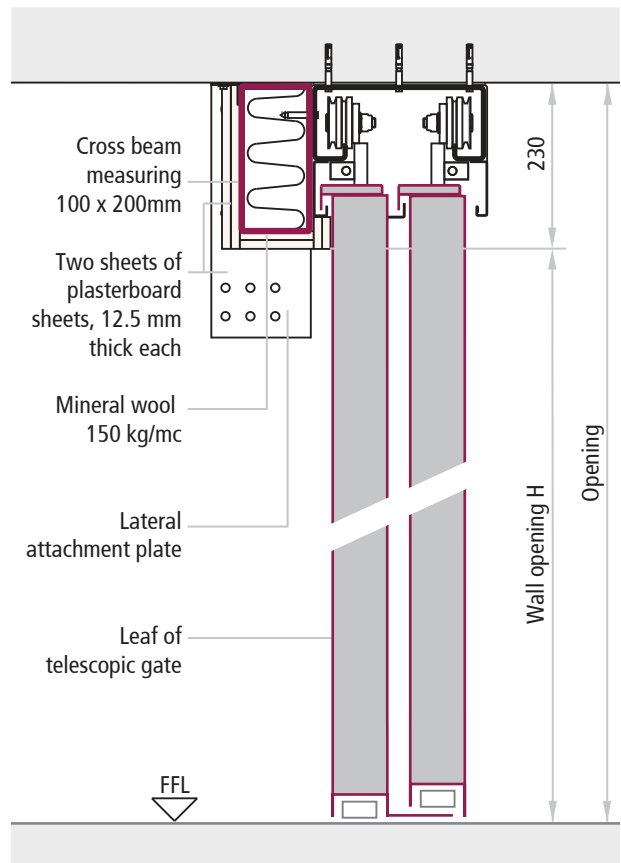

GENERAL NOTES

All rights reserved.
 No reproduction (partial or total) without prior authorization by Ninz. Ninz reserves the right to modify the product.
 Installation should be executed by qualified technicians.
 Modifications may only be made as indicated in the installation instructions.
 Original NINZ replacement parts must be used for all repair work.



**"fire protection
comes from above"**



NINZ vertically sliding gates

FIRE DOORS

FEATURES

194

REI 120 VERTICALLY SLIDING GATES

195

ELECTROMAGNETS, VISCOTROLLER

196

PAINTING

197

All measurements are in mm. We reserve the right to make unannounced technical changes to the contents of this brochure.
Fire rated closures are typically used for internal compartmentalization and have been designed for this purpose.

Features

Vertically sliding gates

WHAT DEFINES THEM?

REI120 fire rated gates are available with a vertically sliding system.

The field of use includes large or small openings and/or special usage conditions in customer-specified dimensions. Gates are supplied with flush insulated sheet metal panes, sliding guides, protective carters, counterweights, thermal fuses or electromagnets and finished with a base coat or RAL colors, plus other accessories as required for correct product functioning.

Standards

The gates are certified in accordance with UNI 9723 standard in compliance with the current ministerial provisions in force.

ATTENTION

Vertically sliding gates are supplied as a single pre-assembled unit, this must be taken into consideration for purposes of handling.

Fire compartmentalization elements should always be used properly. They are only designed for installation in spaces and constructions that are vertically aligned and flush.

Interiors compartmentalization is possible for areas only which are not subject to strong air currents. Installation to be executed by specialized technicians only. For special applications consult with our technical office.

The holding system for the gate is chosen by the customer to conform with their own worksite needs and the anti-fire design (thermal fuse or electromagnet).

NOTE

Fire rated gates require careful design because of their dimensions and special functions. Every installation site should be measured and checked for vertical alignment of the walls and gradients of the flooring. Particular care must be taken to check for protrusions or blockages that might hinder the operation or free movement of the gates. Given the considerable weight of gates, the bearing capacity of the walls involved should be checked for the mounting of guide tracks and overlapping labyrinths.

Vertically sliding gates lift closure is available in classes:

 REI 120



Features

Vertically sliding gates

REI 120 VERSION

The vertically sliding gate series has the following features:

Door leaf

Single unit made of continuous modules of hollow-core sheet metal panels insulated with appropriate materials. Leaf thickness 80 mm.

Guide track

Sliding on lateral guide tracks and flame-resistant anti-friction anti-skid plates.

Overlapping labyrinths

Made of press-folded sheet metal.

Counterweights

Counterweights with adjustable balancing

Door handles

Recessed on both sides.

Sealing

Thermo-expanding on all overlapping labyrinths.

Identification plate

Marking with reference information that is applied directly to the handle.

Finishing

With a base coat thermoset in a 160 degree °C furnace, light turquoise pastel color (similar to NCS4020-B50G).

Wall opening dimensions

Min. 300 X 500 max. 3000 X 3000
Larger sizes on request.

Normal operation mode

The gate remains in the open position, held by a thermal fuse located at the top on the labyrinth distancer. The gate can be closed manually. In case of fire the gate closes as soon as the thermal fuse fails.

Packaging

On disposable metal container.

Weight

REI 120 vertical lift - approx. 50 kg/m² wall opening, excluding guides and counterweights.

NOTE

Additional accessories are usually dependent on the dimensions of the gate

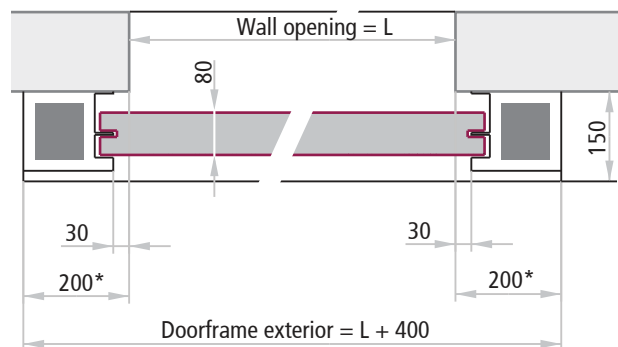
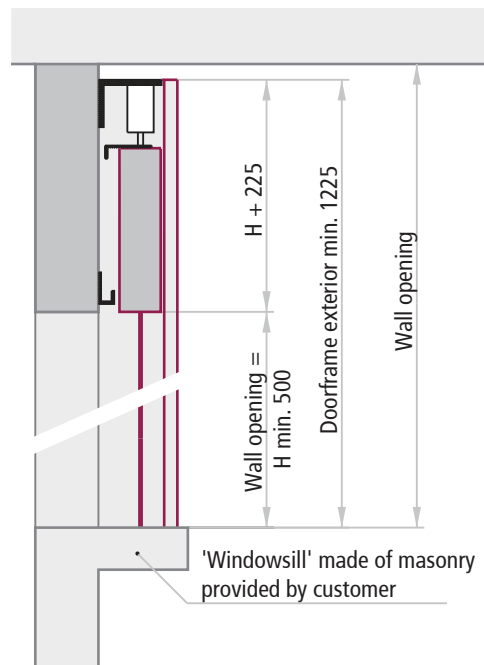
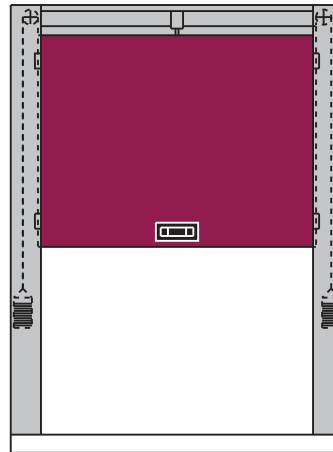

*Variable dimensions for larger-sized gates

Optional accessories

Vertically sliding gates

VT - VISCOTROLER[®] ACCIDENT PREVENTION DEVICE

Gates should always be equipped with an automatic device that controls the feed speed of the door during automatic closing.

After the critical moment when automated re-closure has been initiated, door speed increases progressively in proportion to opening time and door weight. During emergency situations, the energy that develops could cause serious injury/damage to people or objects within its range of motion. The hydraulic V.T. VISCOTROLLER[®] rotor makes it possible to set a constant closing speed in the range of 0.05 to 0,25 m/sec.

ATTENTION

For purposes of accident prevention, gates should always be equipped with a feed-in brake to regulate closing speed. Customers who choose not to include the feed-in brake assume full responsibility for possible consequences.

ELECTROMAGNETS

Gates operation mode with electromagnets (on request): the gate is usually left open. The counterweight is always hooked to the leaf and closure occurs whenever the electric current to the electromagnet is interrupted.

For smoke/heat detection systems, control unit and power supply, see the dedicated page in the accessories doors section of the present brochure.

Technical data for the CC600N electromagnet per leaf up to 1.0 m² of wall opening

primary power supply	24 V DC
voltage tolerance	± 10%
nominal current	125 mA
nominal power	3 W
insertion duration	100%
withstand force	approx. 61 Kg.
operational temperature	0°C ÷ +50°C
operational temperature at 20°C	45°C
magnetic residue	null

Technical data for the CC1400N electromagnet per leaf for more than 1,0 m² of wall opening

primary power supply	24 V DC
voltage tolerance	± 10%
nominal current	200 mA
nominal power	5 W
insertion duration	100%
withstand force	approx. 143 Kg.
operational temperature	0°C ÷ +50°C
operational temperature at 20°C	60°C
magnetic residue	null

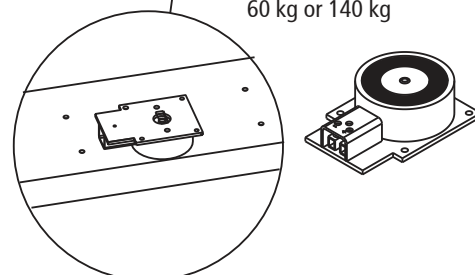
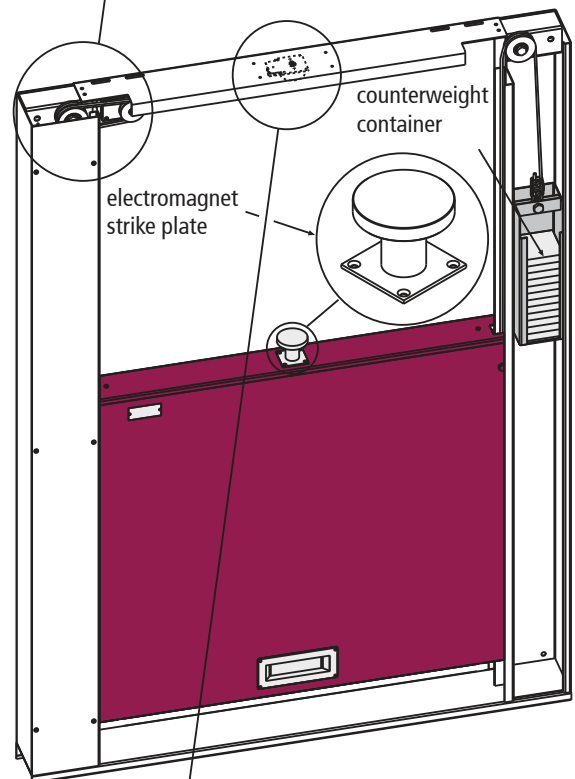
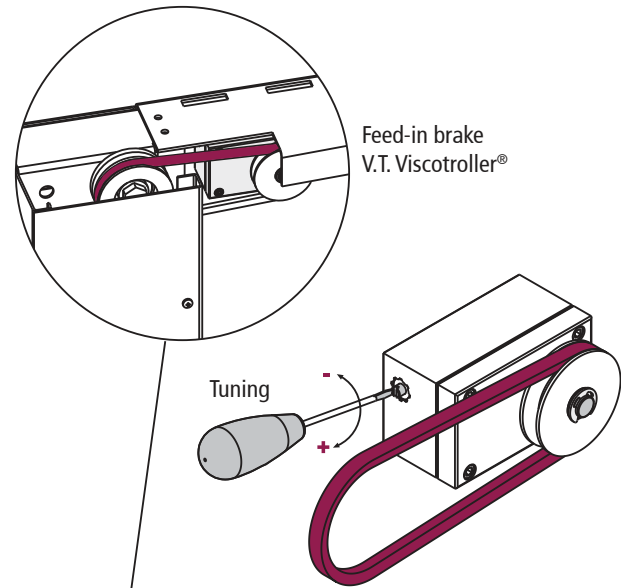

Optional accessories

Vertically sliding gates

PAINTING

With ecologically formulated anti-corrosive epoxide primer. Minimum resistance to salt fog exposure: 300 hours (A.S.T.M. B - 117 - 61). Basic anti-corrosion coating: Light turquoise pastel.

Group 01 (Basic anti-corrosion coating only):

Light turquoise pastel (similar to NCS4020-B50G)

RAL 7035



Group 02 (Basic anti-corrosion coating + satin topcoat finishing):

RAL 1001	RAL 1013	RAL 1015	RAL 3000	RAL 3003	RAL 3020	RAL 5010	RAL 5012
RAL 5015	RAL 5024	RAL 6000	RAL 6005	RAL 7001	RAL 7004	RAL 7011	RAL 7016
RAL 7024	RAL 7030	RAL 7032	RAL 7035	RAL 7037	RAL 7038	RAL 7040	RAL 7042
RAL 7047	RAL 8011	RAL 8017	RAL 8019	RAL 9001	RAL 9002	RAL 9005	RAL 9010
RAL 9011	RAL 9016	RAL 9018					

In general, all RAL colours are useable except for: RAL 1018, RAL 5005 and RAL 9007

Cleaning

Water and neutral soap are recommended for the regular cleaning of our products. Do not use common cleaning products (see detergents) and/or other solvents. We shall not be held responsible for any problems that arise if these guidelines are not respected.

Re-painting

For re-painting, use the following procedure:

- sand and carefully wipe away any dust from the surfaces
- apply a base layer of opaque 2-component epoxide we recommend EPOX product Nr. 5203 beige 0059 made by ALCEA in Milan
- repaint the surfaces with your choice of lacquers or paints.



Group 03 (Basic anti-corrosion coating + satin topcoat finishing):

RAL 1004	RAL 1005	RAL 1006	RAL 1007	RAL 9006*
----------	----------	----------	----------	-----------

*Pre-approval of the sample is required.

Group 04 (Basic anti-corrosion coating + satin topcoat finishing):

RAL 1003	RAL 1012	RAL 1016	RAL 1021	RAL 1023	RAL 5002
----------	----------	----------	----------	----------	----------

NOTE

For printing-related reasons, the colors depicted should only be considered as indicative. Consult the RAL or NCS samples.

Retouching

On request, Ninz also provides touch-up paint (nitro/synthetic) in 1,00 kg cans in the necessary RAL colour.

Protection

Since the gates are designed for internal usage, they should always be protected from atmospheric agents and direct sunlight.

Exterior uses require paints that are specially designed for this type of use (on request).

ATTENTION

External installation of gates require various measures for preventing product degradation, such as:

1. The gates should always be protected from bad weather. Permanent damage may result if water seeps inside the door leaf. Provide canopies or roofing to protect newly installed and existing products.
2. Avoid darker colors for gates which will be exposed to direct sunlight. Sheet metal can heat up and cause warping of the door leaf which could compromise the functionality of the door itself.

GENERAL NOTES

All rights reserved.
No reproduction (partial or total) without prior authorization by Ninz. Ninz reserves the right to modify the product.
Installation should be executed by qualified technicians.
Modifications may only be made as indicated in the installation instructions.
Original NINZ replacement parts must be used for all repair work.

**"simple solutions
for complex needs"**

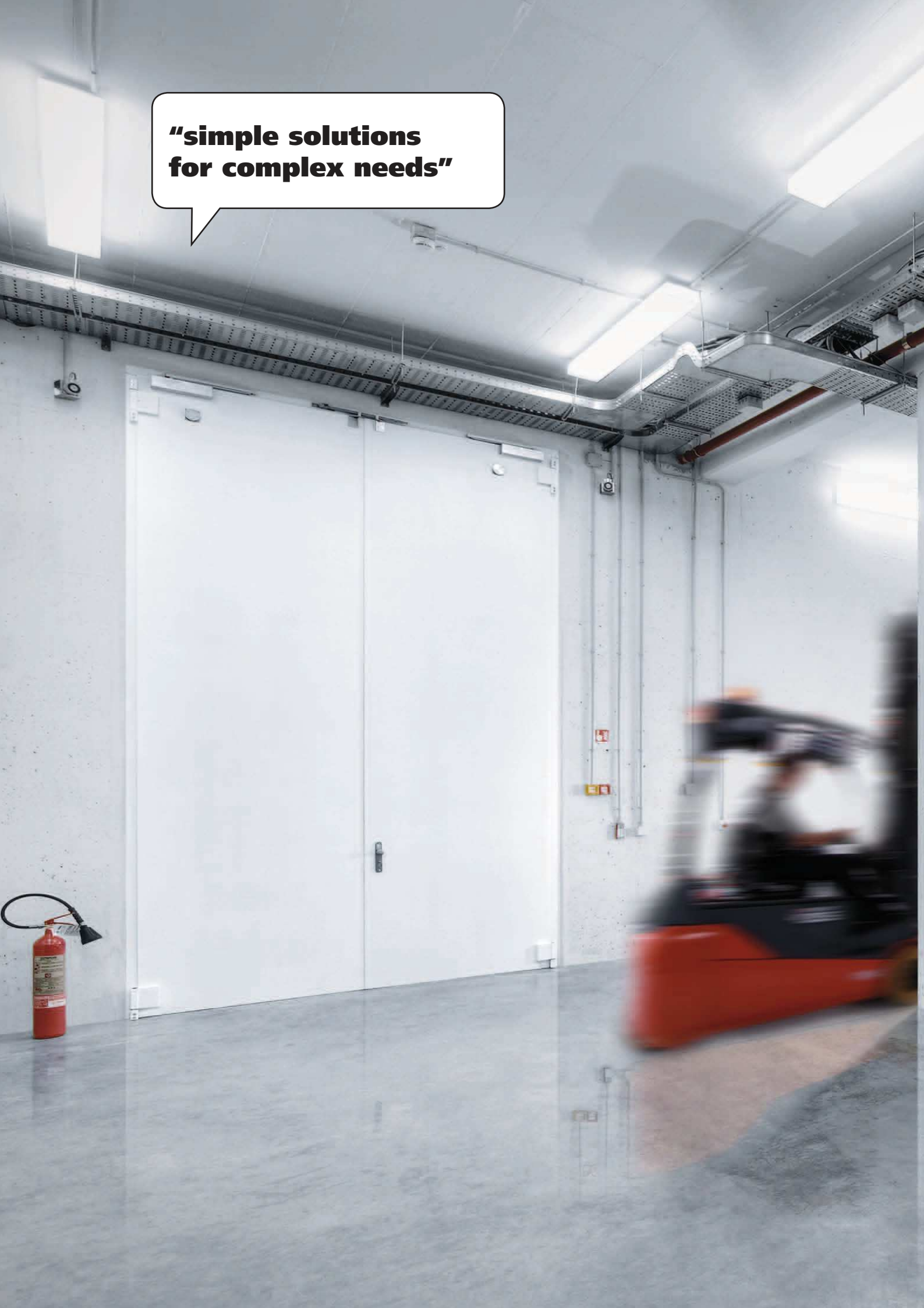

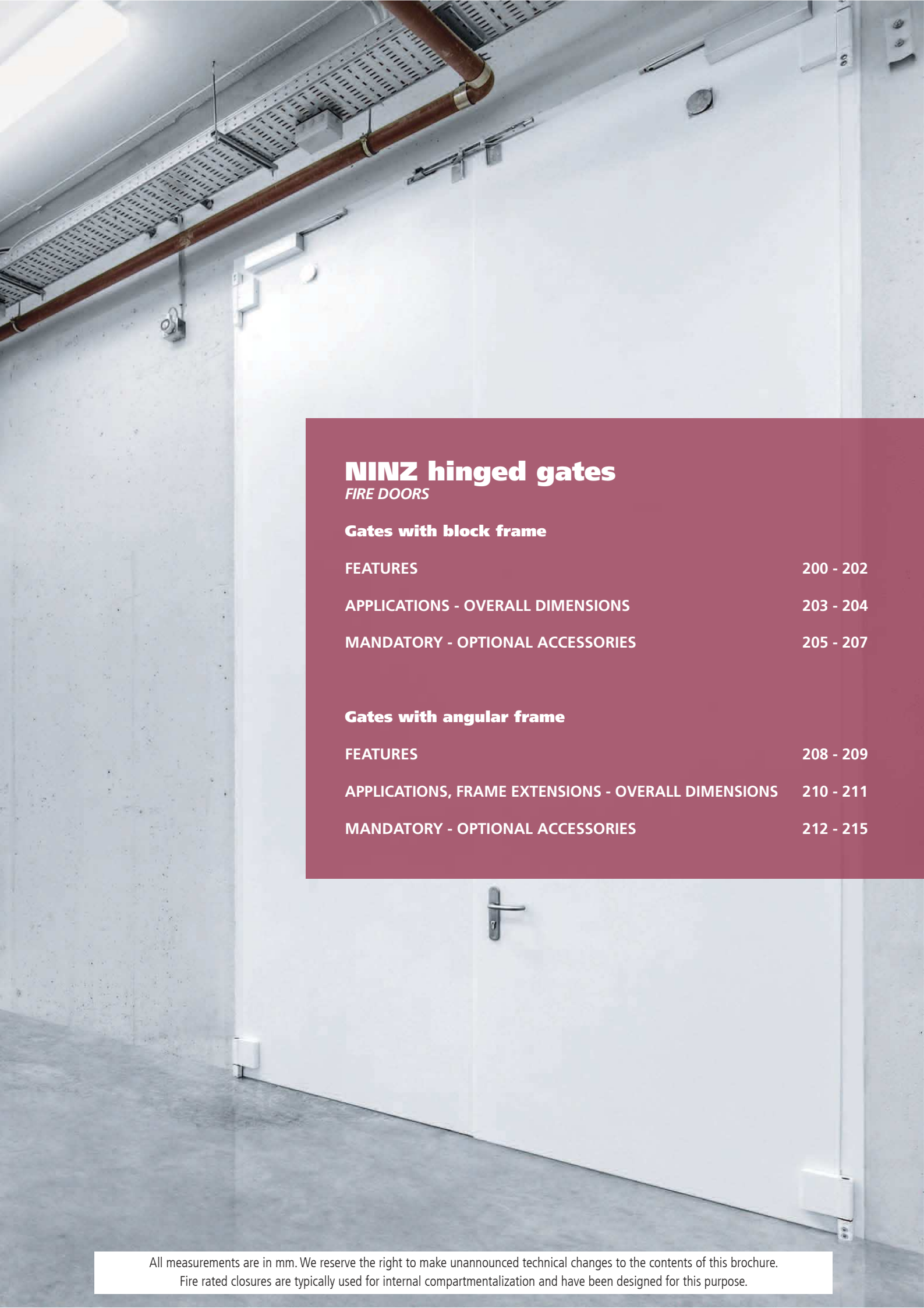

NINZ hinged gates

FIRE DOORS

Gates with block frame

FEATURES	200 - 202
APPLICATIONS - OVERALL DIMENSIONS	203 - 204
MANDATORY - OPTIONAL ACCESSORIES	205 - 207

Gates with angular frame

FEATURES	208 - 209
APPLICATIONS, FRAME EXTENSIONS - OVERALL DIMENSIONS	210 - 211
MANDATORY - OPTIONAL ACCESSORIES	212 - 215

Features

Hinged gates with block frame

WHAT DEFINES THEM?

The field of use includes large openings and/or special usage conditions in customer-specified dimensions. Gates are supplied with leaves made of flush insulated sheets of metal panes, jointed and attached to each other with screws, "L"-profile block frame on three sides and finished with a base coat or RAL colours and other accessories as required for proper functioning of the product.

Standards

The gates are certified in accordance with UNI 9723 standard in compliance with the current ministerial provisions in force.

Opening direction, pull

Opening direction needs to be specified while ordering.

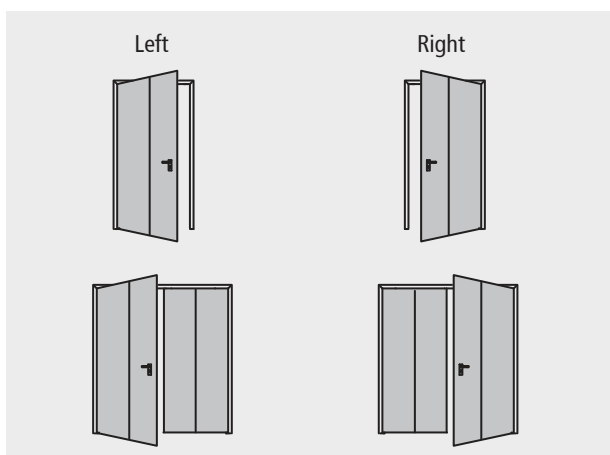

NOTE

Fire rated gates require careful design because of their dimensions and special functions. Every installation site should be measured and checked for vertical alignment of the walls and gradients of the flooring. Given the considerable weight of gates, the bearing capacity of the walls should also be checked.

ATTENTION

Gates are supplied as a single pre-assembled unit, this should be kept in mind for purposes of handling. The customer assumes all risks entailed by the use of Hinged gates along escape routes.

Fire compartmentalization elements should always be used properly. They are only designed for installation in spaces and constructions that are vertically aligned and flush.

Interiors compartmentalization is possible for areas only which are not subject to strong air currents. Installation to be executed by specialized technicians only. For special applications consult with our technical office.

Hinged one-leaved gate with block frame:



Hinged two-leaved gate with block frame:



Features

Hinged gates with block frame

REI 120 ONE-LEAVED VERSION

This hinged gates series has the following features:

Application

For masonry walls, use plugs inside the span and corner steel outside the span (to be specified while ordering).

Door leaf

Leaf unit made of continuous modules of hollow-core sheet metal panels insulated with appropriate materials, without lower rebate. Leaf thickness 72 mm. Nr. 2 extra-strong hinges for each leaf.

Doorframe

Made of galvanize "L"-shaped hollow metal profiles.

Hinges

Nr. 2 extra-strong hinges.

Sealing

Thermo-expansive, inserted into the leaf rebate.

Door handle

Accident-prevention shape, made of stainless steel with a double lever with return spring and set of plates. Handle height = 1050 mm.

Lock

CE marked lock with cylinder to pass.

Identification plate

Marking with reference information that is applied to the leaf's rebate.

Finishing

With a base coat thermoset in a 160 degree °C furnace, light turquoise pastel color (similar to NCS4020-B50G).

Packaging

Leaf unit on disposable metal container.

Wall opening dimensions

Min. 1000 X 1750 mm, max. 5000 X 2500 mm, larger sizes on request.

Mandatory accessories

1 CE-marked door closer per leaf.

Maximum opening

120° with door closer only, and 110° additional coil spring.

Weight

Gate weight, approx. 60 kg/m² of wall opening.

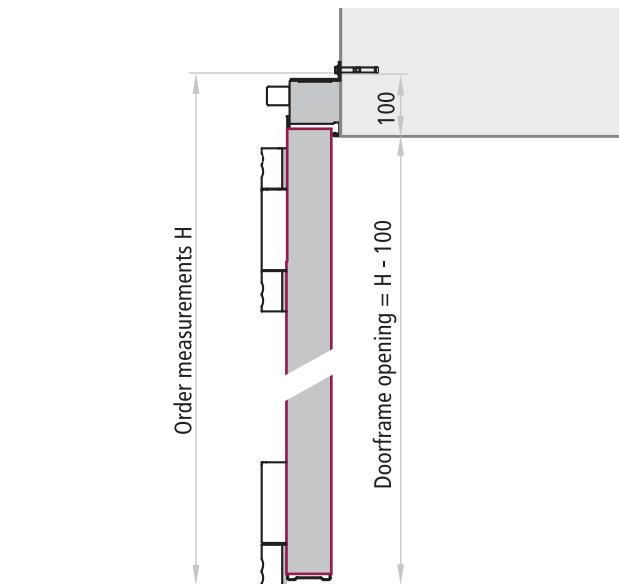
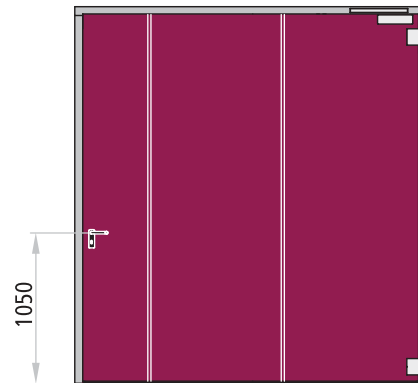

Vertical section for installation with block frame

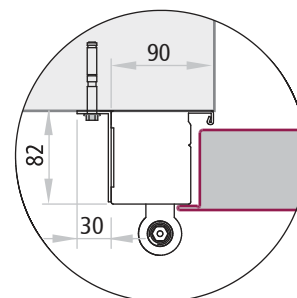
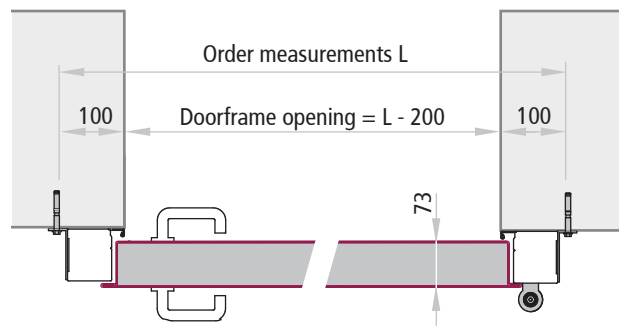

Detail of section for installation with block frame

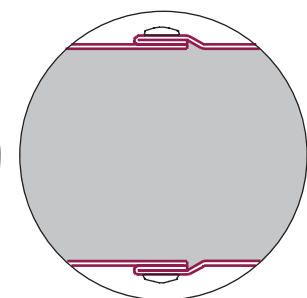

Detail of panel joints

Features

Hinged gates with block frame

REI 120 TWO-LEAVED VERSION

This two-leaved vertically hinged gates series has the following features:

Installation

For masonry walls, use plugs inside the span and corner steel outside the span (to be specified while ordering).

Door leaf

Leaf unit made of continuous modules of hollow-core sheet metal panels insulated with appropriate materials, without lower rebate. Leaf thickness 72 mm. Unequal divisions available on request.

Doorframe

Made of galvanized "L"-shaped hollow metal profiles.

Hinges

Nr. 2 extra-strong hinges for each leaf.

Sealing

Thermo-expansive, inserted into the leaf rebate.

Door handle

Accident-prevention shape, made of stainless steel with a double lever with return spring and set of plates. Handle height = 1050 mm.

Lock

Active (main) leaf: **CE** marked lock with cylinder to pass
Secondary leaf: "Flush-bolt" lock for automatic upper and lower blocking of the leaf.

Identification plate

Marking with reference information that is applied to the rebate of one of the leaves.

Finishing

With a base coat thermoset in a 160 degree °C furnace, light turquoise pastel color (similar to NCS4020-B50G).

Packaging

Leaf unit on disposable metal container.

Wall opening dimensions

Min. 2000 X 1750 mm, max. 5000 X 5000 mm, larger sizes on request.
Minimum division: 1000 mm.

Mandatory accessories

1 door closer per leaf and 1 closing regulator for proper sequencing of leaf closure.

Maximum opening

120° with door closer only, and 110° additional coil spring.

Weight

Gate weight, approx. 60 kg/m² of wall opening.

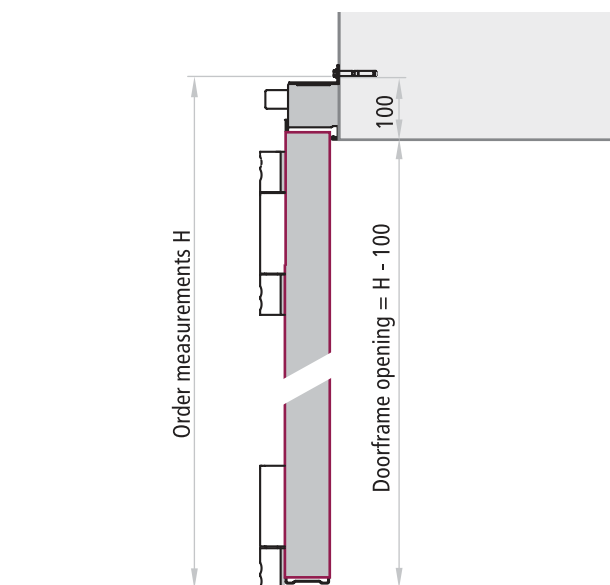
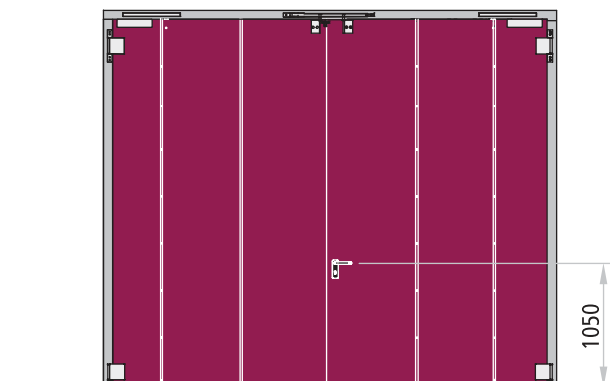

Vertical section for installation with block frame

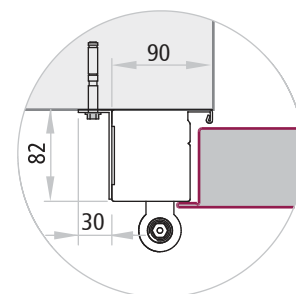
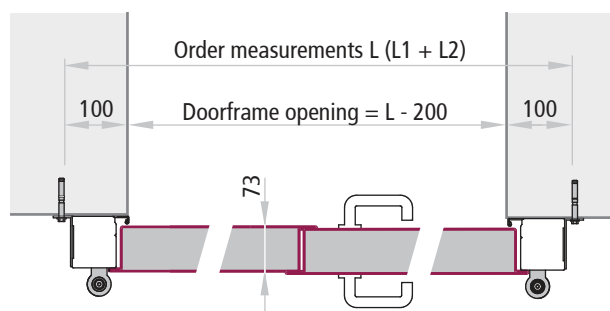

Detail of section for installation with block frame

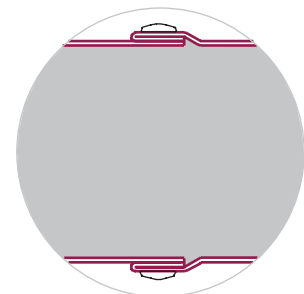

Detail of panel joints with block frame

Applications and overall dimensions

Hinged one-leaved gate with block frame



HINGED gates

ONE-LEAVED INSTALLATION BEYOND THE REVEAL

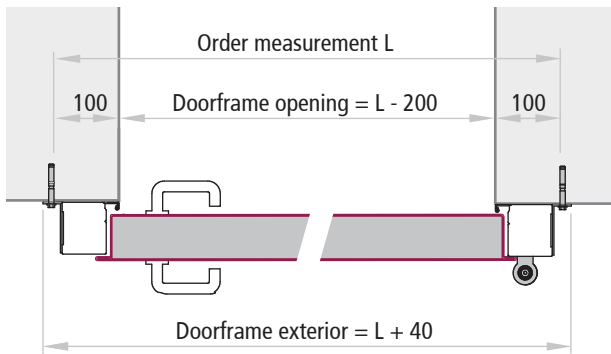
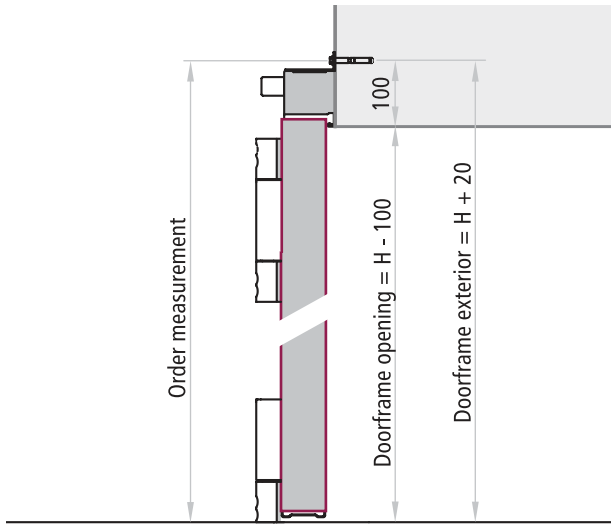

ONE-LEAVED INSTALLATION IN THE REVEAL

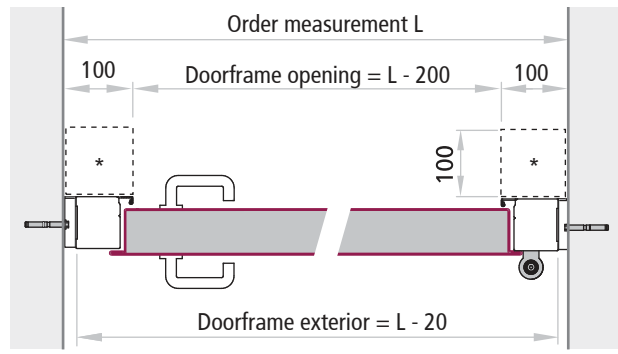
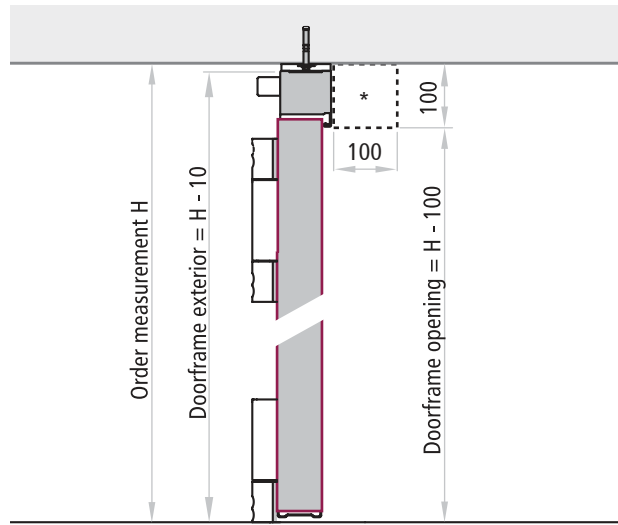

ONE-LEAVED DOOR OVERALL DIMENSIONS WITH 90° OPENING

*After the gate has been installed, the building of the additional apron is the buyer's responsibility and duty

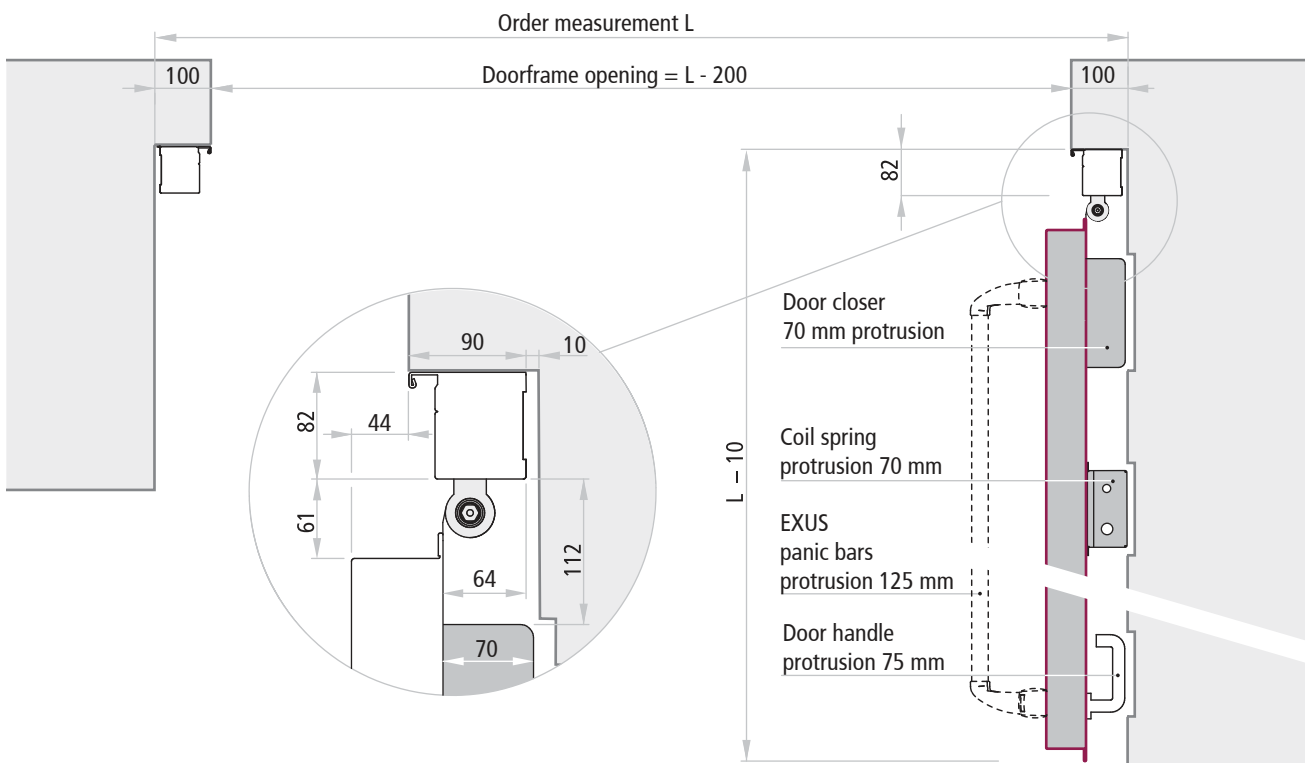

Applications and overall dimensions

Hinged two-leaved gates with block frame

TWO-LEAVED INSTALLATION BEYOND THE REVEAL

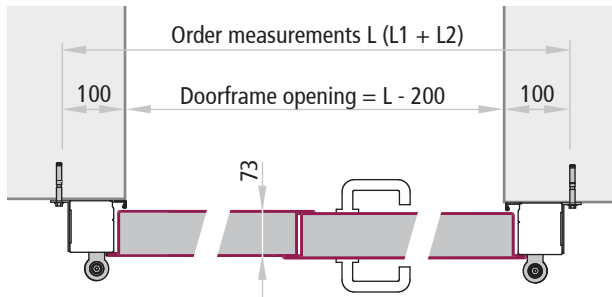
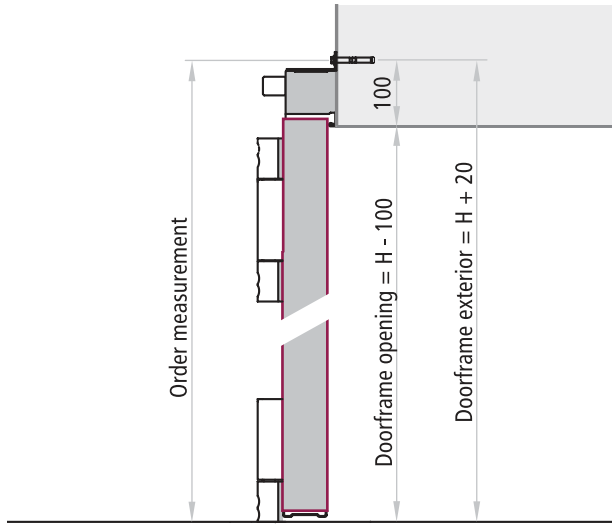

TWO-LEAVED INSTALLATION IN THE REVEAL

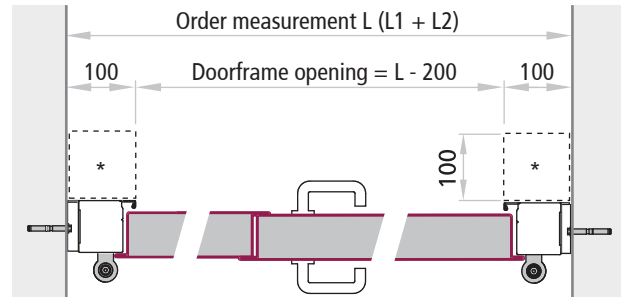
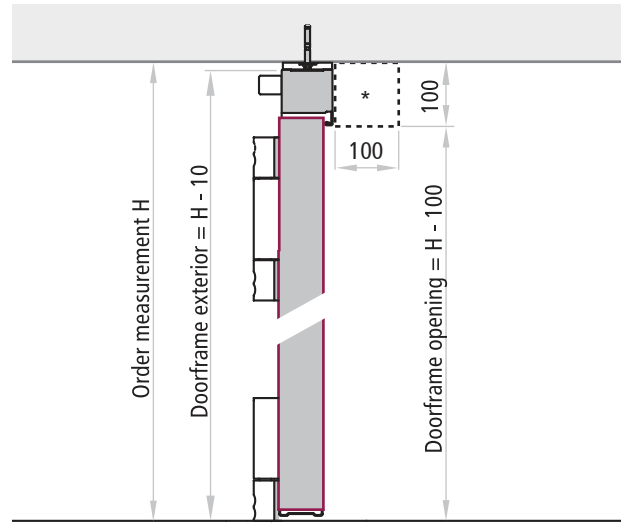

*After the gate has been installed, the building of the additional apron is the buyer's responsibility and duty

TWO-LEAVED DOOR OVERALL DIMENSIONS WITH 90° OPENING

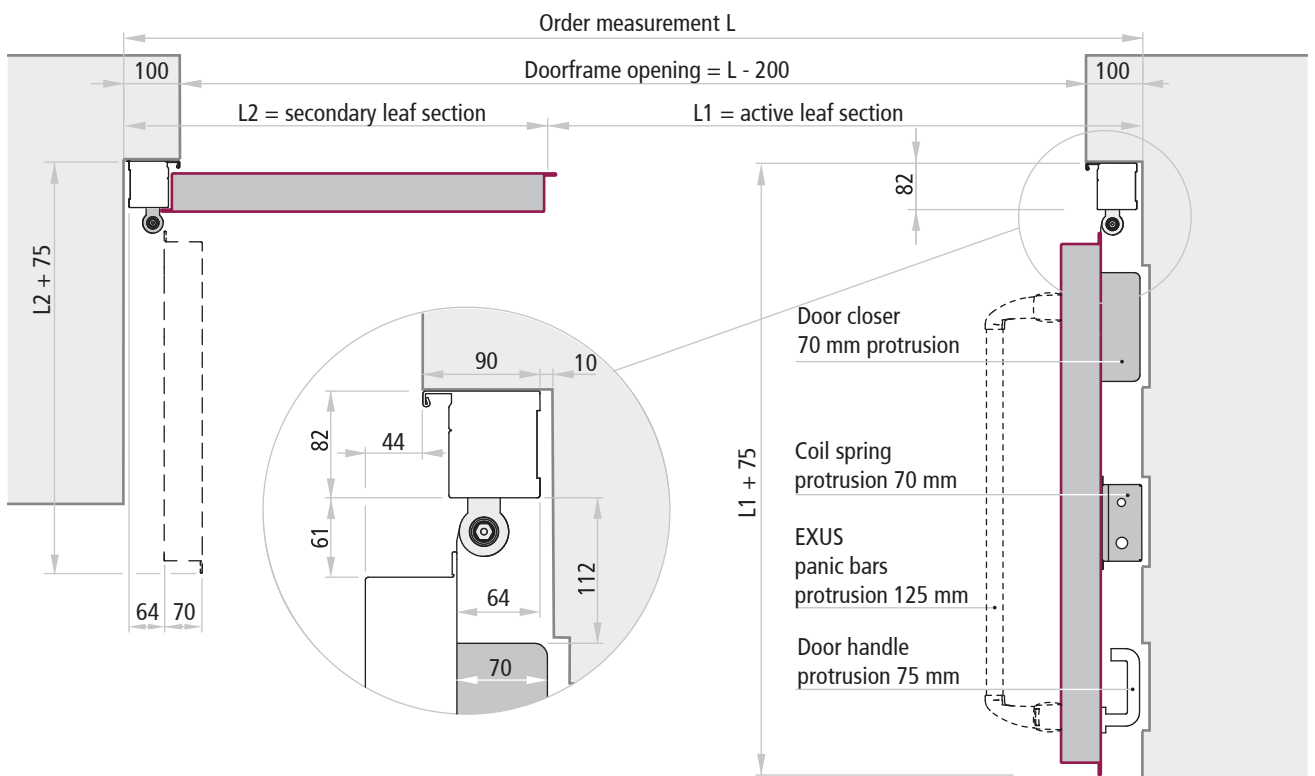

Mandatory accessories

Hinged gates with block frame

TS93 DOOR CLOSER

Door closer (1) with slide channel for large sizes, with regulation of opening force, closing velocity and final closure. Silver color.

CE certification 0432-BPR 0008 EN 1154:1996 + A1:2002

SR390 CLOSING REGULATOR

To ensure automatic closure of two-leaved fire rated gates, a door closing regulation is mandatory. The two-leaved gates door series, therefore, is provided with a Dorma SR 390 closing regulator (2), equipped with feed-in impact absorber and all mechanical functioning, mounted visibly on the doorframe. Silver-colored galvanized finishing, for on-site installation.

CE certification 0432-BPR 0026 EN 1158:1997+A1:2002

COIL SPRING

Coil spring (3) for large sized leaves to reinforce the door closer, with mechanical functioning and positioned high up on the hinge-side of the leaf (pull-side of the door). The steel tension cable is attached to the cross beam of the doorframe. Finished in the same color as the door leaf (except for replacements).

NOTE

The accessories require assembly.

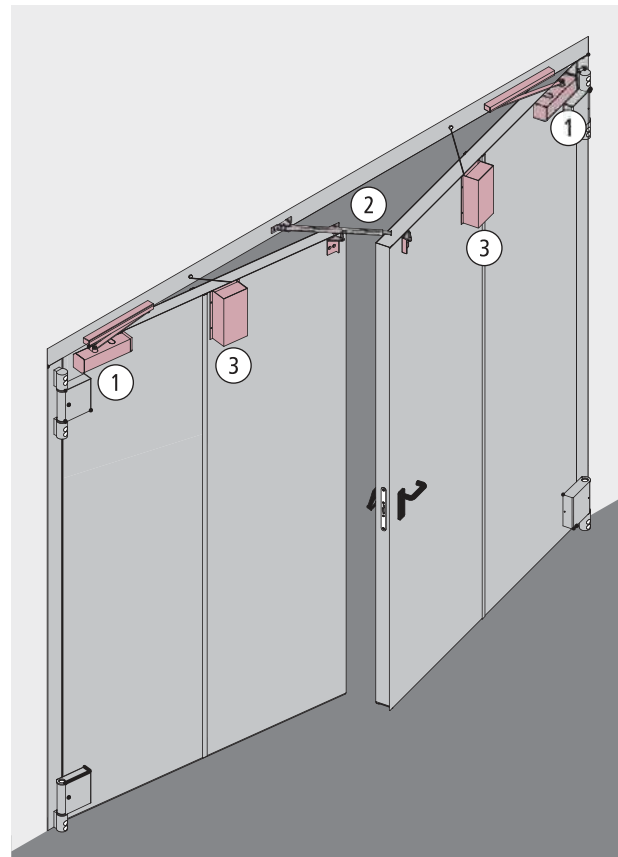

Optional accessories

Hinged gates with block frame



PAINTING

With ecologically formulated anti-corrosive epoxide primer. Minimum resistance to salt fog exposure: 300 hours (A.S.T.M. B - 117 - 61). Basic anti-corrosion coating: Light turquoise pastel.

Group 01 (Basic anti-corrosion coating only):

Light turquoise pastel (similar to NCS4020-B50G)

RAL 7035

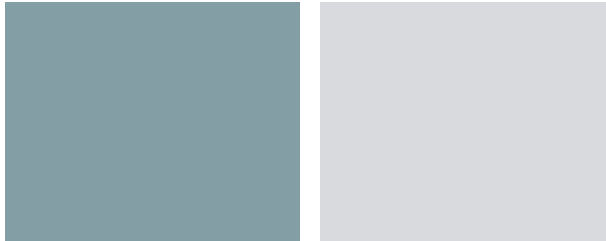

Group 02 (Basic anti-corrosion coating + satin topcoat finishing):

RAL 1001	RAL 1013	RAL 1015	RAL 3000	RAL 3003	RAL 3020	RAL 5010	RAL 5012
RAL 5015	RAL 5024	RAL 6000	RAL 6005	RAL 7001	RAL 7004	RAL 7011	RAL 7016
RAL 7024	RAL 7030	RAL 7032	RAL 7035	RAL 7037	RAL 7038	RAL 7040	RAL 7042
RAL 7047	RAL 8011	RAL 8017	RAL 8019	RAL 9001	RAL 9002	RAL 9005	RAL 9010
RAL 9011	RAL 9016	RAL 9018					

In general, all RAL colours are useable except for: RAL 1018, RAL 5005 and RAL 9007

Cleaning

Water and neutral soap are recommended for the regular cleaning of our products. Do not use common cleaning products (see detergents) and/or other solvents. We shall not be held responsible for any problems that arise if these guidelines are not respected.

Re-painting

For re-painting, use the following procedure:

- sand and carefully wipe away any dust from the surfaces
- apply a base layer of opaque 2-component epoxide - we recommend EPOX product Nr. 5203 beige 0059 made by ALCEA in Milan
- repaint the surfaces with your choice of lacquers or paints.



Group 03 (Basic anti-corrosion coating + satin topcoat finishing):

RAL 1004	RAL 1005	RAL 1006	RAL 1007	RAL 9006*
----------	----------	----------	----------	-----------

*Pre-approval of the sample is required.

Group 04 (Basic anti-corrosion coating + satin topcoat finishing):

RAL 1003	RAL 1012	RAL 1016	RAL 1021	RAL 1023	RAL 5002
----------	----------	----------	----------	----------	----------

In general, all RAL colours are useable except for: RAL 1018, RAL 5005 and RAL 9007

NOTE

Due to artifacts of the printing process, the colors depicted here may not correspond exactly to the colors of actual doors. Please see the RAL or NCS samples.

Retouching

On request, Ninz also provides touch-up paint (nitro/synthetic) in 1,00 kg cans in the necessary RAL colour.

Protection

Since the gates are designed for internal usage, they should always be protected from atmospheric agents and direct sunlight.

Exterior uses require paints that are specially designed for this type of use (on request).

ATTENTION

External installation of gates require various measures for preventing product degradation, such as:

1. The gates should always be protected from bad weather. Permanent damage may result if water seeps inside the door leaf. Provide canopies or roofing to protect newly installed and existing products.
2. Avoid darker colors for gates which will be exposed to direct sunlight. Sheet metal can heat up and cause warping of the door leaf which could compromise the functionality of the door itself.

Optional accessories

Hinged gates with block frame

CC600N AND CC1400N WALL-MOUNTED ELECTROMAGNETS WITH STRIKE PLATE ANCHORS

For smoke/heat detection systems, central control units and power supply, see the dedicated page in the accessories section of the present brochure.

Technical data for the CC600N electromagnet per leaves up to 5 m² of wall opening with a maximum leaf width of 1700 mm

primary power supply	24 Vcc
voltage tolerance	± 10%
nominal current	125 mA
nominal power	3 W
insertion duration	100%
withstand force	approx. 61 Kg.
operational temperature	0°C ÷ +50°C
operational temperature at 20°C	45°C
magnetic residue	null

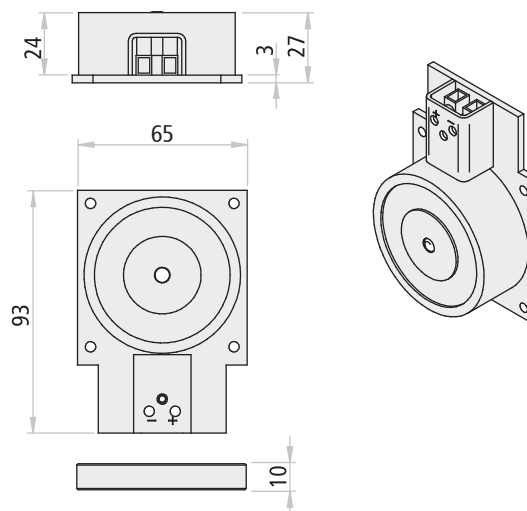

Technical data for the CC1400N electromagnet for leaves up to 5 m² of wall opening or with leaf width greater than 1700 mm

primary power supply	24 Vcc
voltage tolerance	± 10%
nominal current	200 mA
nominal power	5 W
insertion duration	100%
withstand force	approx. 143 Kg.
operational temperature	0°C ÷ +50°C
operational temperature at 20°C	60°C
magnetic residue	null

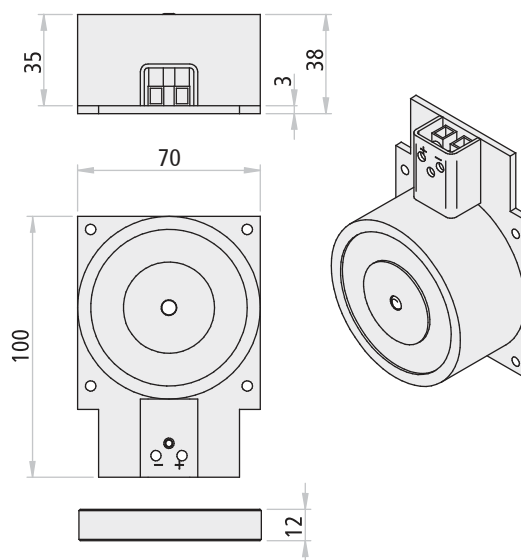

NOTE

Position the anchor 200 mm from the external edge of the leaf and as far as possible from the hinges.

CE marked in conformity with STANDARD EN 1155

EXUS LP/LX AND TWIST PANIC BARS

For more information, please see the "panic bars" section of the present brochure. Certification: suited for one-leaved gates or the active and passive leaves of two-leaved gates with dimensions up to 1350 x 2880 mm/leaf and masses of 300 kg/leaf. Height of central bar: 955mm in case of Exus; 965mm in case of Twist.

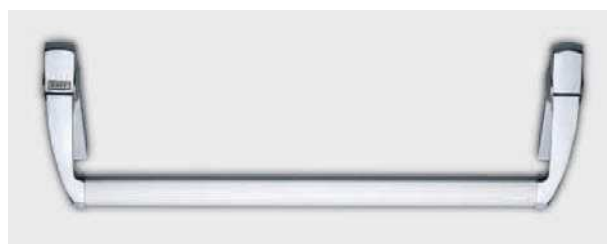

Exus LX

Features

Hinged gates with angular frame

WHAT DEFINES THEM?

The field of use includes large openings and/or special usage conditions in customer-specified dimensions. Gates are supplied with leaves made of flush insulated sheets of metal panes soldered together, "Z"-profile angular frame on three sides and finished with a base coat or RAL colours and other accessories as required for proper functioning of the product.

Standards

The hinged gates are certified in accordance with UNI 9723 standard.

Those WITH PEDESTRIAN DOOR are certified in accordance with UNI EN 1634 standard.

Both gates are homologated in compliance with the current ministerial provisions in force.

Opening direction, pull

Opening direction needs to be specified while ordering.

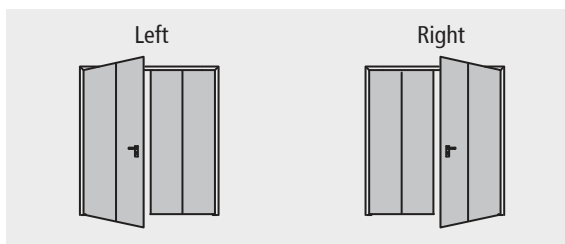

NOTE

Fire rated gates require careful design which reflects their dimensions and special functions. Every installation site should be measured and checked for vertical alignment of the walls and gradients of the flooring. Given the considerable weight of gates, the bearing capacity of the walls should also be checked.

ATTENTION

Gates are supplied as a single pre-assembled unit, this should be kept in mind for purposes of handling. The customer assumes all risks entailed by the use of Hinged gates along escape routes.

Fire compartmentalization elements should always be used properly. They are only designed for installation in spaces and constructions that are vertically aligned and flush.

Interiors compartmentalization is possible for areas only which are not subject to strong air currents. Installation to be executed by specialized technicians only. For special applications consult with our technical office.

Hinged two-leaved gate with angular frame:



Features

Hinged gates with angular frame

REI 120 TWO-LEAVED VERSION EI₂120 TWO-LEAVED VERSION WITH PEDESTRIAN DOOR

This hinged gates has the following features:

Application

For solid walls with installation with wall anchors or screws and plugs or for frames installed onto sub-frame with plasterboard lining.

Door leaves

Leaf unit made of continuous modules of hollow-core sheet metal panels insulated with the appropriate materials, without lower rebate. Leaf thickness 73 mm. Unequal divisions available on request.

Doorframe

Made of galvanized sheet metal with a "Z"-shaped hollow metal profiles.

Hinges

Nr. 2 extra-strong drain-type hinges for each leaf.

Sealing

Thermo-expansive, inserted into the leaf rebate.

Door handle

Accident-prevention shape, made of stainless steel with a double lever with return spring and set of plates. Handle height = 1050 mm.

Lock

Active (main) leaf: **CE**-marked lock with cylinder to pass
Secondary leaf: "Flush-bolt" lock for automatic upper and lower blocking of the leaf.

Identification plate

Marking with reference information that is applied to the rebate of one of the leaves.

Finishing

With thermoset epoxy-polyester powders, with orange skin anti-scratch finishing, turquoise pastel color - light tone (NCS4020-B50G) for gates maximum H = 5000 mm.

Packaging

Leaf unit on disposable metal container.

Dimensions L x H

Min. 2000 x 1750 mm, max. 6000 x 5000 mm, larger sizes on request.
Minimum division: 650 mm.

Mandatory accessories

1 door closer per leaf and 1 closing regulator for proper sequencing of leaf closure.

Maximum opening

120° with door closer only.

Weight

Gate weight, approx. 60 kg/m² of wall opening.

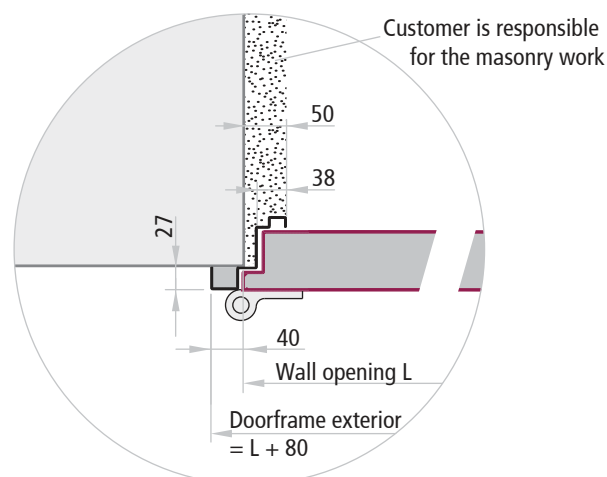
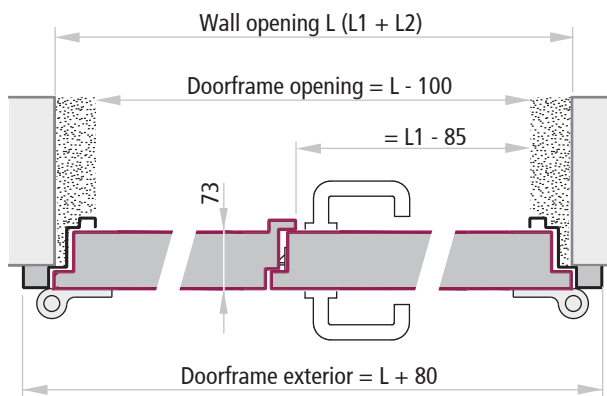
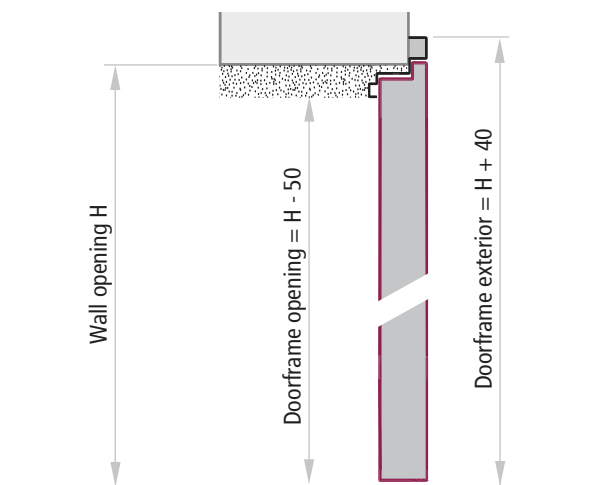
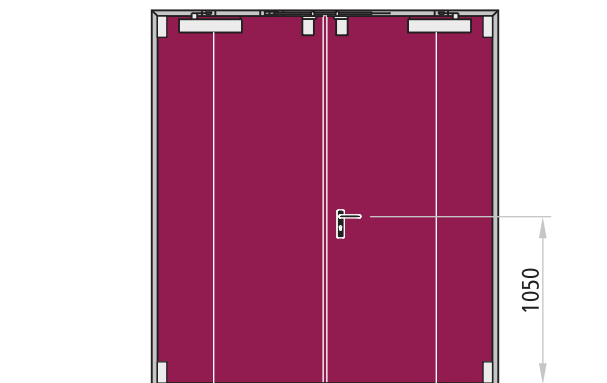

Applications

Hinged two-leaved gates with angular frame



DOORFRAME WITH ANCHORS FOR MORTAR FIXING OR FIXING WITH SCREWS AND PLUGS

Vertical cross section

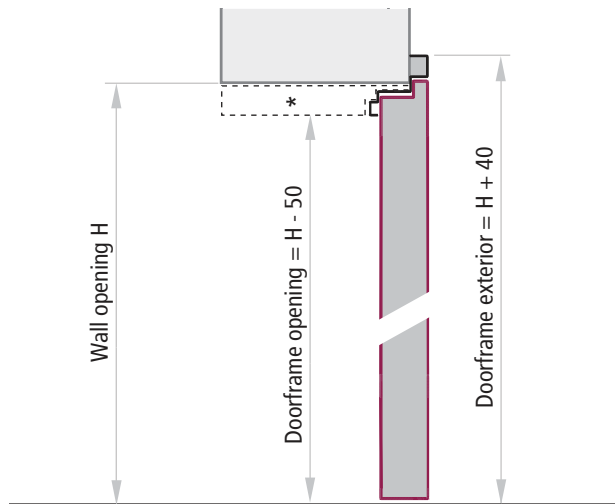

Horizontal cross section

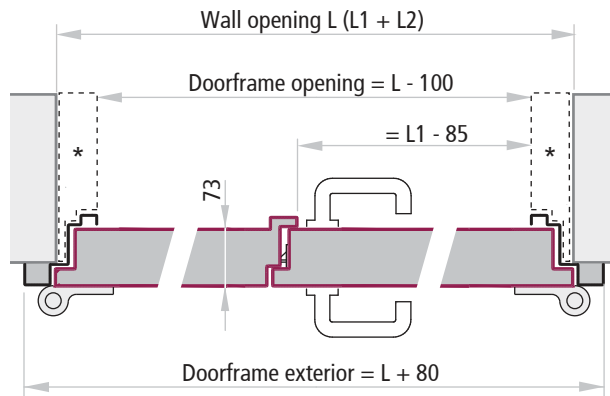

* Isolation of the doorframe or lining with frame extension IG 1 to be done by the customer.

SUBFRAME-MOUNTED DOORFRAME - IN THE REVEAL APPLICATION

Vertical cross section

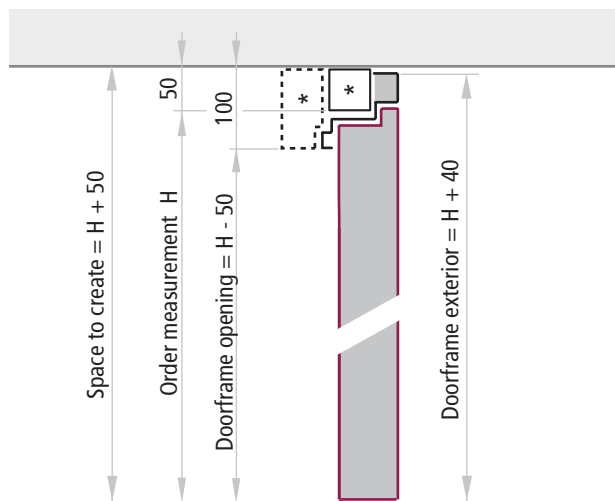

Horizontal cross section

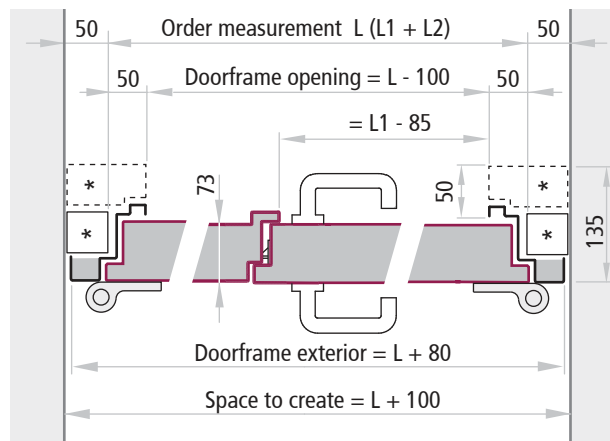

* Subframe 50x50 and plasterboard finishing are the customer's responsibility unless ordered separately (see frame extension IG 3).

Frame extensions - Overall dimensions

Hinged two-leaved gates with angular frame



HINGED gates

FRAME EXTENSIONS FOR GATES WITH ANGULAR FRAME

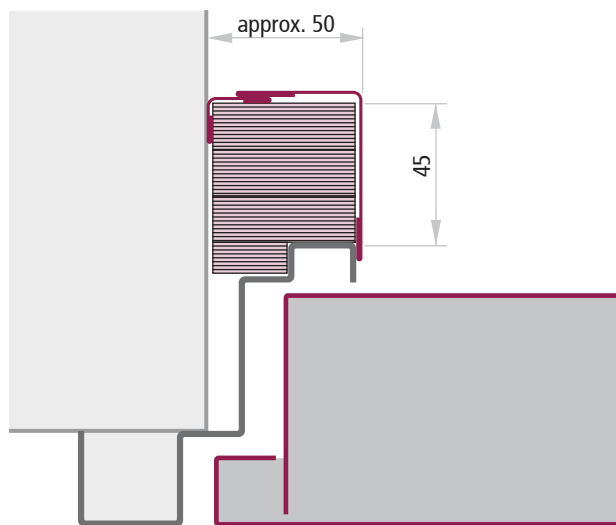

IG 1
Frame extension covering on three sides the door frame installed with wall anchors or screws and plugs. Supplied with plasterboard sheets to be installed on site, painted with epoxy-polyester powder in the same colour as the leaf.

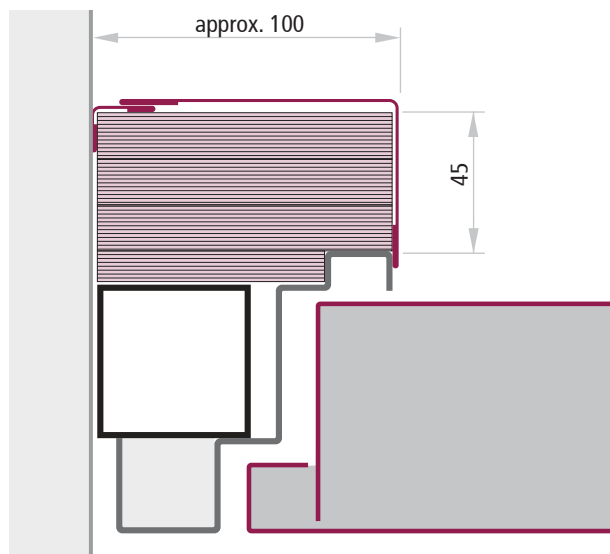

IG 3
Frame extension covering on three sides the door frame installed onto sub-frame. Supplied with plasterboard sheets to be installed on site, painted with epoxy-polyester powder in the same colour as the leaf.

TWO-LEAVED DOOR OVERALL DIMENSIONS WITH 90° OPENING

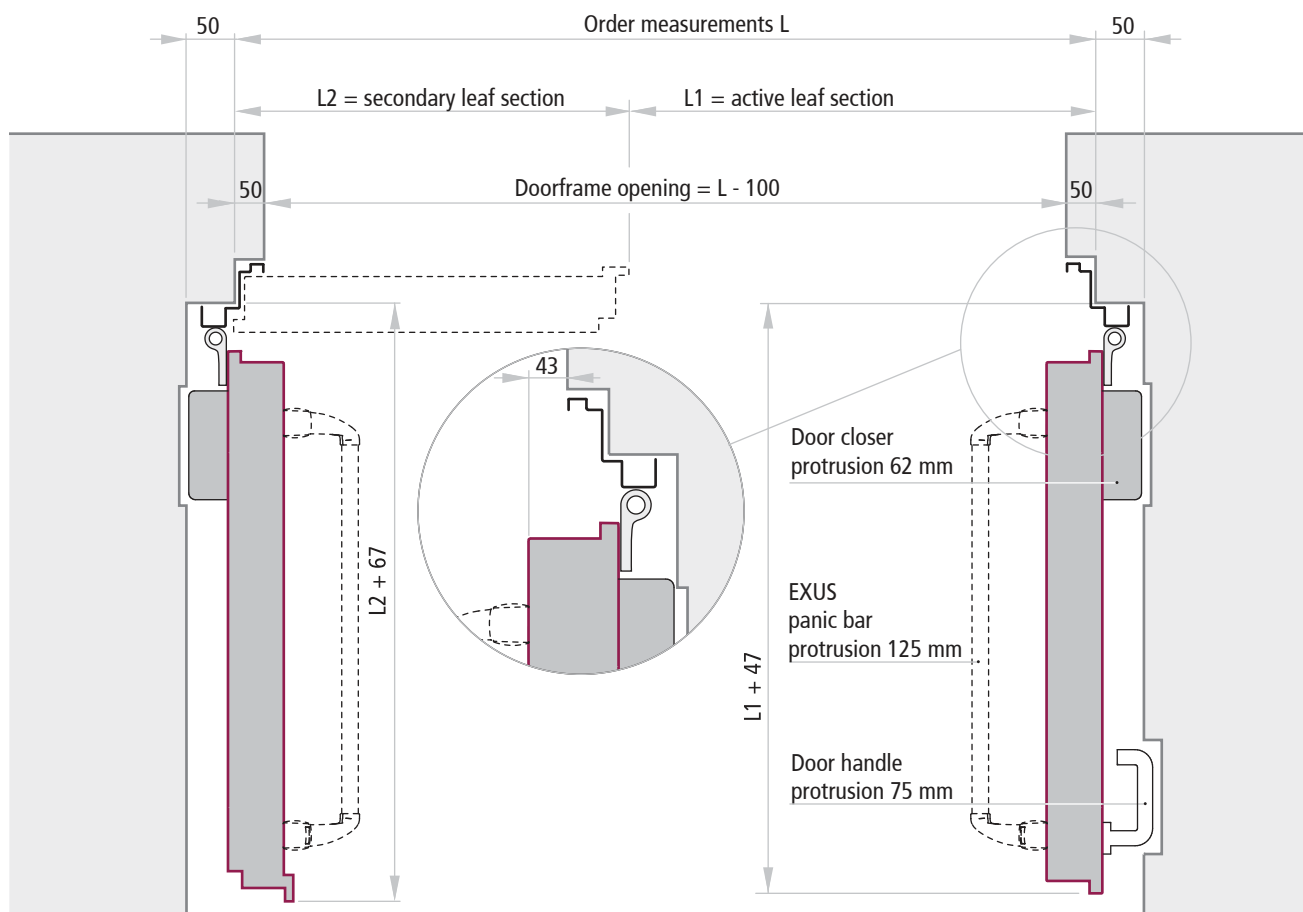

Mandatory accessories

Hinged gates with angular frame

RYOBI D-3550 DOOR CLOSER

The RYOBI D-3550 door closer has a 2 to 6 force range that can be adjusted by means of a convenient external tuning screw, is ambidextrous and is available with different accessories and color choices. It comes with an ABS design cover with a standard scissor arm.

It is also available with slide-channel, which requires ordering the D-3550T series door closer.

The RYOBI D-3550 door closer has two screws for separate regulation of the closing speed and the feed-in speed increase. It is also equipped with a regulator screw for deceleration while opening, to avoid shocks to the door, and a regulator screw for delaying the initiation of the closing cycle.

RYOBI D-3550 door closers are guaranteed for 2,000,000 operational cycles, and are certified for use with fire doors BS476 part 22/87 ANSI A 156.4 grade 1 UL and ADA, and as further assurance of their quality they are also CE marked 1720-CPD-0001 Rev A in accordance with EN 1154.

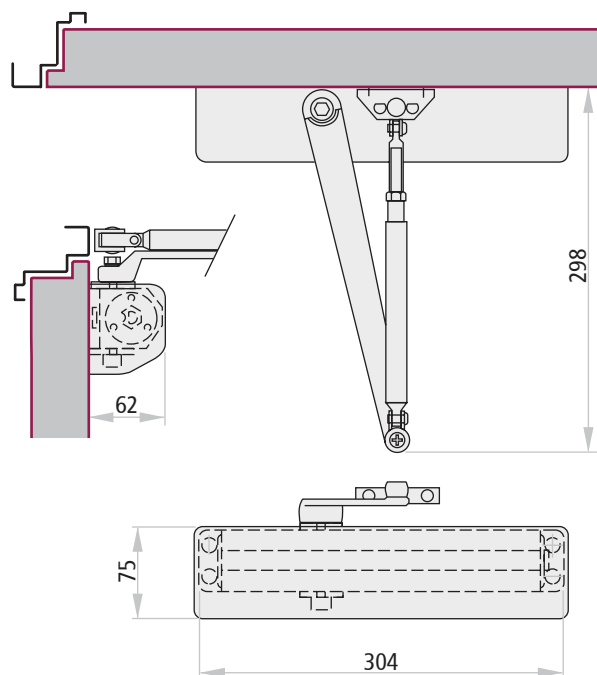

SR90 CLOSING REGULATOR

To ensure automatic closure of two-leaved fire rated gates, a door closing regulators obligatory. The two-leaved fire gates series, therefore, is provided with a Dictator SR90 closing regulator, equipped with feed-in impact absorber and all-mechanical functioning, mounted visibly on the doorframe. Silver-colored galvanized finishing and for on-site installation.

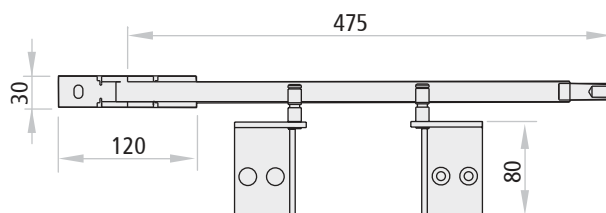

CE Certification 0432-BPR 0109.02 EN 1158:1997/A1:2004/04

VS 2000 SHOCK ABSORBER

For large doors to soften the final shock of door closure, positioned on the hinge-side of the leaf. The strike plate is attached to the doorframe.

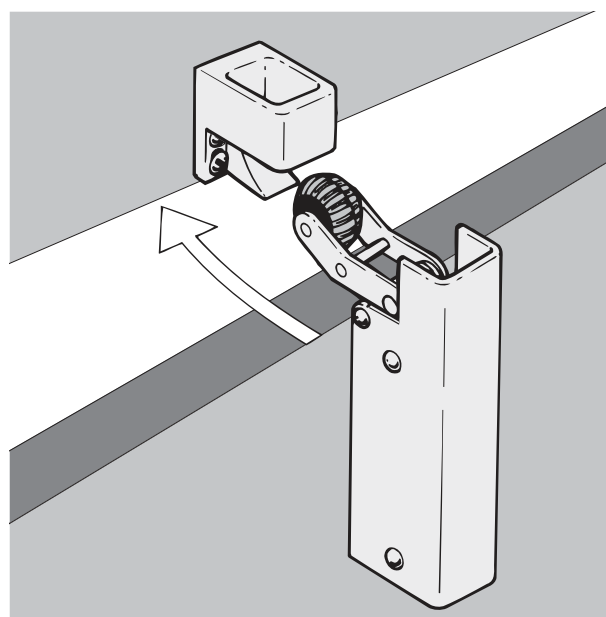
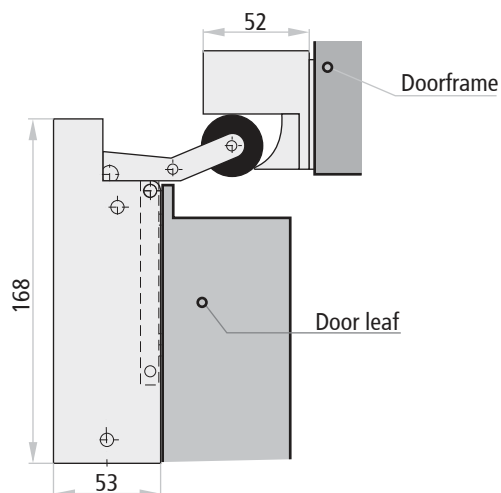

NOTE
The accessories require assembly.

Optional accessories

Hinged gates with angular frame

ELECTROMAGNET 70 KG WALL-MOUNTED WITH STRIKE PLATE

EM wall-mounted electromagnet with white plastic casing and unlock button. Anchor consisting of a nickel-plated plate and jointed baseboard. For smoke/heat detection systems, control unit and power supply, see the dedicated page in the accessories doors section of the present brochure.

Technical data

power supply	24 Vcc
absorption	67 mA
minimum withstand force	approx. 71 kg

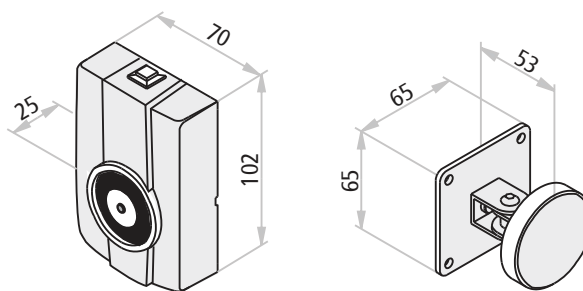

CE marked in conformity with STANDARD EN 1155.

EXUS LP/LX, TWIST, SLASH AND SLASH INOX PANIC BARS

For more information, please see the "panic bars" section of the present brochure. Certification: suited for one-leaved gates and the active and secondary leaves of two-leaved gates with dimensions up to 1350 x 2880 mm/leaf and masses of 300 kg/leaf.

Height of central bar from finished floor surface: 955mm for Exus; 965mm for Twist; 1050mm for Slash.

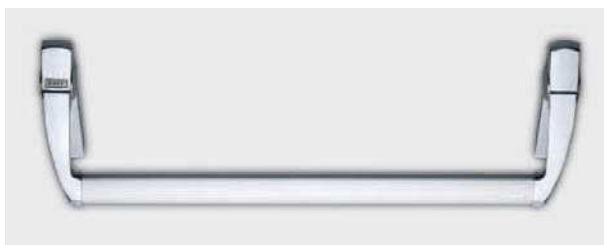

Exus LX in stainless steel



Slash with carter cover in black plastic

PEDESTRIAN DOOR WITH 15mm THRESHOLD

El₂120 two-leaved hinged gates with angular doorframe can be equipped with pedestrian doors with a lower threshold. The right or left opening direction should be chosen by the customer and indicated while ordering. The pedestrian door series is for insertion into the secondary leaf. It opens towards the hinge-side of the gate and can be equipped with a window, on request.

For additional information concerning the panic exit device, please see the dedicated pages in the panic exit device section of the present brochure.

Minimum dimensions (L2 and FM H) for the insertion of pedestrian doors:

Pedestrian door size	minimum dimensions
width 900	L2 > 1680
width 1140	L2 > 1980
height 2000	FMH > 2230

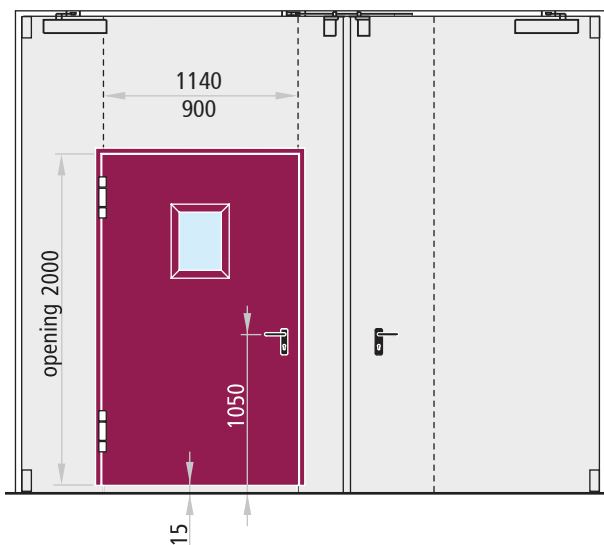

ATTENTION

Because of the bottom threshold, even though of small dimensions, in case of installation into emergency exit routes at the discretion of the customer, the latter shall assume all responsibilities.

Painting

The hinged gates series of gates is painted with thermoset powders, with anti-scratch finish and semi-glossy embossing (except for certain colors). The paint is especially resistant and offers a pleasant finish for interior applications. Choose from a wide range of RAL colors.



STANDARD COLORS WITH NO PRICE SUPPLEMENT

Interior painting with epoxy-polyester powders in turquoise pastel - light tone (NCS4020- B50G). The tonalities of the frame and the door leaf are represented in the photo to the side

Group 01:

color NCS 4020-B50G



SPECIAL COLORS WITH NO PRICE SUPPLEMENT

Interior paints available in a variety of RAL colours with epoxy-polyester powders.

Group 02:

RAL	RAL	RAL	RAL	RAL	RAL
1013	5010	7035	9001	9002	9010

Group 03:

RAL	RAL	RAL	RAL	RAL	RAL	RAL	RAL
1015	5024	6000	7016	7024	7038	8011	9011

RAL	RAL
9016	9018

SPECIAL COLORS WITH PRICE SUPPLEMENT

Interior paints available in a variety of RAL colours with epoxy-polyester powders.

Group 04:							
RAL	RAL	RAL	RAL	RAL	RAL	RAL	RAL
1001	1003	3000	3003	3020	5012	5015	6005
RAL	RAL	RAL	RAL	RAL	RAL	RAL	RAL
7001	7004	7011	7030	7032	7037	7040	7042
RAL	RAL	RAL	RAL	RAL	RAL		
7047	8017	8019	9005	9006*	9007*		

SPECIAL COLORS FOR EXTERIOR USE WITH PRICE SUPPLEMENT

Exterior painting with polyester powders in various RAL colours.

Group 05:							
RAL	RAL	RAL	RAL	RAL	RAL	RAL	RAL
1013E	3000E	5010E	6005E	7016E	7024E	7035E	9002E
RAL	RAL	NCS	NCS				
9006E*	9010E	4020E	5020E				

*pre-approval of the sample is required.

SPECIAL COLORS BY REQUEST WITH PRICE SUPPLEMENT

Painting available for interior and exterior with epoxy-polyester and polyester (respectively) powders in the requested RAL colours. Group 05 does not include special colors, such as metallic, mica, smooth or wrinkled texture and other sample colours like Pantone, NCS, etc.

Group 05:							
Colors by request only							

Cleaning

Water and neutral soap are recommended for the regular cleaning of our products. Do not use common cleaning products (see detergents) and/or other solvents. We shall not be held responsible for any problems that arise if these guidelines are not respected.

NOTE

Due to artifacts of the printing process, the colors depicted here may not correspond exactly to the colors of actual doors. Please see the RAL or NCS samples.

Re-painting

For re-painting, use the following procedure:

- sand and carefully wipe away any dust from the surfaces
- apply a base layer of opaque 2-component epoxide we recommend EPOX product Nr. 5203 beige 0059 made by ALCEA in Milan
- repaint the surfaces with your choice of lacquers or paints.

Retouching

On request, Ninz also provides touch-up paint (nitro/synthetic) in 0,50 kg cans in the necessary RAL colour.

WARNING!

External installation of gates require various measures for preventing product degradation, such as:

1. The gates should always be protected from bad weather. Permanent damage may result if water seeps inside the door leaf. Provide canopies or roofing to protect newly installed and existing products.

Protection

Since the gates are designed for internal usage, they should always be protected from atmospheric agents and direct sunlight.

Exterior uses require paints that are specially designed for this type of use (see group 04 and 05).

2. Avoid darker colors for gates which will be exposed to direct sunlight. Sheet metal can heat up and cause warping of the door leaf which could compromise the functionality of the door itself.

GENERAL NOTES

All rights reserved.

No reproduction (partial or total) without prior authorization by Ninz. Ninz reserves the right to modify the product.

Installation should be executed by qualified technicians.

Modifications may only be made as indicated in the installation instructions.

Original NINZ replacement parts must be used for all repair work.